



# HERNANDO COUNTY, FLORIDA PROPERTY RECORD CARD

## 2023 PRELIMINARY TAX ROLL

<b>KEY #</b>	00155316	<b>PRINTED ON</b>	09/29/23	<b>PAGE</b>	1
<b>PARCEL #</b>	R12 223 16 1900 0000 0020	<b>SITUS</b>	3236 GULF WINDS CIR		
<b>OWNER(S)</b>	RAMOS FRANCISCO, RAMOS LINDA	<b>PARCEL DESCRIPTION</b>	GULF COAST RET UNIT 2 LOT 2		
<b>MAILING ADDRESS</b>	3236 GULF WINDS CIR HERNANDO BEACH FL 34607-3024	<b>UPDATED</b>	ORB 327 PG 431 01/01/80		
<b>UPDATED</b>	07/02/10				

MISCELLANEOUS PROPERTY INFORMATION		
SQUARE FOOTAGE	11,093	
ACRES	0.30	
JURISDICTION	C	COUNTY
LEVY CODE	CWES	COUNTY WIDE EMS
NEIGHBORHOOD	GF01	GULF FRONT ZONE 1
SUBDIVISION	1900	GULF COAST RET UNIT 2
DOR LAND USE	01	SINGLE FAMILY
NON-AD VALOREM DIST1	36	H.C. FIRE/RESCUE DISTRICT
NON-AD VALOREM DIST2	65	HERNANDO BEACH - SHOAL LINE BLV
NON-AD VALOREM DIST3	99	SOLID WASTE DISPOSAL MSBU



2023-01-00 PROPERTY VALUES				
	COUNTY	SCHOOL	SWFWMD	MUNICIPALITY
LAND	534,200	534,200	534,200	
BUILDINGS	1,117,768	1,117,768	1,117,768	
FEATURES AND OUT BUILDINGS	46,766	46,766	46,766	
JUST/MARKET VALUE	1,698,734	1,698,734	1,698,734	
VALUE PRIOR TO CAP	1,698,734	1,698,734	1,698,734	
ASSESSED VALUE	737,131	737,131	737,131	
EXEMPT VALUE	50,000	25,000	50,000	
<b>TAXABLE VALUE</b>	<b>687,131</b>	<b>712,131</b>	<b>687,131</b>	
CLASSIFIED LAND USE VALUE				

EXEMPTIONS BY TAXING AUTHORITY								
CODE	DESCRIPTION	L.UPDT	CAP.YR	COUNTY	SCHOOL	SWFWMD	MUNICIPALITY	EXT.TAX SAVINGS
HXX	HOMESTEAD	2023	2011	YES	YES	YES		379.69
HXZ	ADDITIONAL HOMESTEAD	2023	2011	YES		YES		221.19
TOTAL:								600.88

LAND INFORMATION												
CODE	DESCRIPTION	AG	LAST UPDT	CAP YEAR	EXC CAP	GRA DE	FRON TAGE	DEPTH	UNITS	MEASURE	ADJ RATE	VALUE
02	RESIDENTIAL	N	2018	2011	N				11,093.00	SQFT	45.38	503,400
S4	SEAWALL, CONC POURE	N	2002	2011	N				220.00	UNITS	140.00	30,800

BUILDING 01 INFORMATION									
NUMBER	1	YEAR BUILT	2010	CAP YEAR	2010	STORIES	3.0		
CODE	01	DEPRECIATION %	05%	EXCL.FROM CAP?	N	ROOMS	8		
DESC	SINGLE FAMILY RESIDENCE	ADD'l DEPREC.	0%			BEDROOMS	3		
L.UPDT	2022	OVERRIDE RATE				BATHROOMS	3		

BUILDING 01 CONSTRUCTION			
ELEMENT	CODE	DESCRIPTION	POINTS
FOUNDATION		STILTS	
EXTERIOR WAL		BLOCK/STUCCO	
FRAME		CRT REINF	
FLOOR SYSTEM		WOOD	
FLOOR COVER		HDWD/TILE	
ROOF STRUCTR		MANSARD	

BUILDING 01 AREAS									
CODE	BASE /AUX	CAP YEAR	EXC CAP	RATE	PERI METER	SQFT SIZE	REPLACEMENT COST	DEPRECIATED VALUE	
OPF	A		N		92.00	340.00	18,204	17,294	
OPF	A		N		38.00	78.00	4,176	3,967	
BAS	B		N		254.00	2620.00	467,618	444,237	
USF	B		N		276.00	2196.00	391,942	372,345	
OPF	A		N		48.00	108.00	5,782	5,493	
OPF	A		N		58.00	180.00	9,637	9,155	



# HERNANDO COUNTY, FLORIDA PROPERTY RECORD CARD

2023 PRELIMINARY TAX ROLL

<b>KEY #</b>	00155316	<b>PRINTED ON</b>	09/29/23	<b>PAGE</b>	2
--------------	----------	-------------------	----------	-------------	---

ROOF COVER	CEMENT TILE	
INTERIOR	DRY WALL	
HTG & AC	PKG HEAT/AIR	

GRF	A	N		246.00	2572.00	252,468	239,845
OPF	A	N		172.00	500.00	26,770	25,432
TOTAL				8,594.00	1,176,597	1,117,768	
ADJUSTED				6,592.00			
BASE				4,816.00			
AUXILIARY				3,778.00			

**January 2022 BUILDING 01 DRAWING**

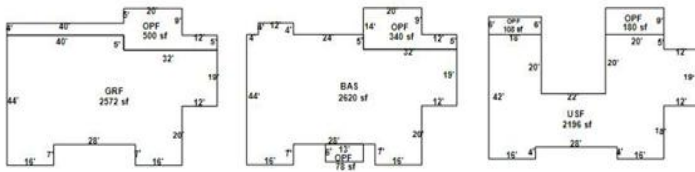

**December 2018 BUILDING 01 PHOTO**



155316 12/19/2018



# HERNANDO COUNTY, FLORIDA PROPERTY RECORD CARD

2023 PRELIMINARY TAX ROLL

<b>KEY #</b>	00155316	<b>PRINTED ON</b>	09/29/23	<b>PAGE</b>	3
--------------	----------	-------------------	----------	-------------	---

## MAGNIFIED BUILDING 01 DRAWING

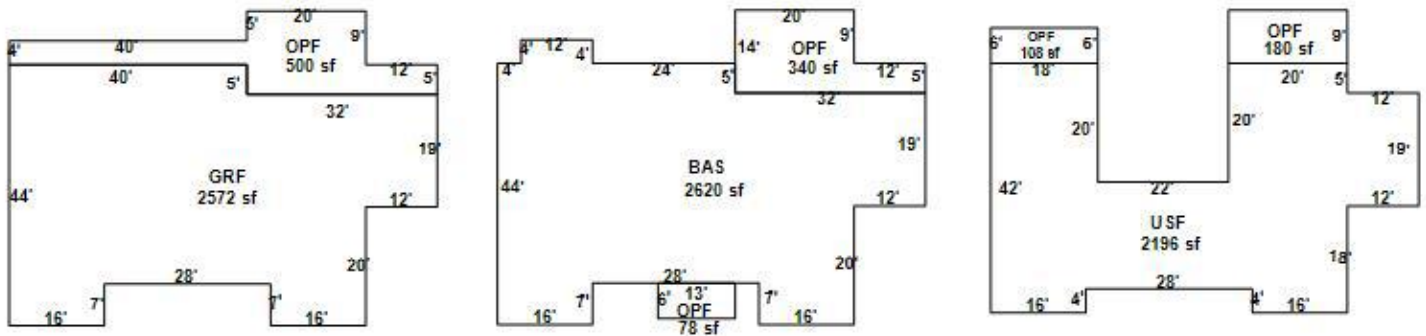

### BUILDING 01 FEATURES

CODE	DESCRIPTION	YEAR BUILT	WIDTH	LENGTH	UNITS	REPLACEMENT COST	DEPRECIATED VALUE
DK1-1	DOCK, BOAT/WOOD	2020	12	15	180	3,240	2,592
DK1-2	DOCK, BOAT/WOOD	2020	4	7	28	504	403
FP3-1	FIREPLACE, LARGE	2010			1	3,600	3,600
PT1-1	PATIO, BRICK/FLAGST	2012	15	52	780	4,212	4,212
PT1-2	PATIO, BRICK/FLAGST	2012	16	20	320	1,728	1,728
PV1-1	PAVEMENT, CONCRETE	2010	28	44	1232	4,435	4,435
PV1-2	PAVEMENT, CONCRETE	2010	14	20	280	1,008	1,008
PV1-3	PAVEMENT, CONCRETE	2010	12	28	336	1,210	1,210
SP4-1	POOL, GUNITE/CONCRET	2012	16	32	512	24,730	21,760
WTT-1	WHIRLPOOL/HOT TUB	2012			1	3,600	3,600

### BUSINESSES ON PROPERTY

KEY #	BUSINESS NAME	NAICS	BUSINESS TYPE
-------	---------------	-------	---------------

### ADDRESSES ON PROPERTY

SITUS
3236 GULF WINDS CIR

### BUILDING PERMITS

APPLIC. #	APP. DATE	PERMIT #	CODE	DESCRIPTION	ISSUED	STATUS	FINALED	VALUE
1453999	12/28/22	1453999	DK	DECK	01/31/23	FINALED	06/26/23	68,000
1441759	06/06/22	1441759	HA	RESIDENTIAL HTG/AIR	06/06/22	FINALED	06/15/22	7,480



# HERNANDO COUNTY, FLORIDA PROPERTY RECORD CARD

2023 PRELIMINARY TAX ROLL

<b>KEY #</b>	00155316	<b>PRINTED ON</b>	09/29/23	<b>PAGE</b>	4
--------------	----------	-------------------	----------	-------------	---

1411823	03/16/21	1411823	RREC	ROOF RECOVER	04/29/21	FINALED	09/29/21	18,704
1385592	11/20/19	1385592	DK	DECK	02/27/20	VOID		68,000
1354007	03/05/18	1354007	HA	RESIDENTIAL HTG/AIR	03/05/18	FINALED	03/09/18	6,200
1283932	05/15/13	1283932	MI	MISCELLANEOUS	06/18/13	FINALED	06/23/14	1,280
1280868	02/22/13	1280868	DO	DOCK	03/25/13	FINALED	06/23/14	7,987
1264873	12/02/11	1264873	ZFN	ZP: FENCE	12/02/11	FINALED	05/22/12	2,300
1259084	06/24/11	1259084	SW	SWIMMING POOL	07/06/11	FINALED	02/28/12	31,840
1252195	11/30/10	1252195	SP	LAWN IRRIGATION, RES.	11/30/10	FINALED	12/17/10	700
1250427	10/06/10	1250427	SE	SEAWALL	10/25/10	FINALED	04/26/11	2,400
1232844	04/20/09	1232844	LP	L P GAS	05/05/09	FINALED	02/09/10	2,200
1232248	03/31/09	1232248	SW	SWIMMING POOL	04/24/09	EXPIRED		31,840
1218125	12/17/07	1218125	SF	SINGLE FAMILY RES.DETACH	02/08/08	FINALED	04/30/10	600,000
1202701	12/19/06	1202701	SE	SEAWALL	01/04/07	FINALED	04/18/07	2,400
0082886	07/29/93	9307720	SE	SEAWALL	08/06/93	CLOSED		2,000

### PROPERTY SALES

SALE DATE	NEW OWNER	CODE	DESCRIPTION	VAC?	INST	OR BOOK	OR PAGE	SALEGRP	VALUE
09/12/03	RAMOS FRANCISCO	Q	QUALIFIED	Y	WD	1743	1894		349,900
08/17/99	TACKETT VIRGINIA A & HOMER G	D	DISQUALIFIED	Y	WD	1298	1975		100
09/16/97	TACKETT HOMER G & VIRGINIA A	D	DISQUALIFIED	Y	CW	1148	0148		100
08/26/97	TACKETT HOMER G & VIRGINIA A	D	DISQUALIFIED	Y	WD	1145	0229		100
01/01/80	TACKETT HOMER G ET UX	Q	QUALIFIED	Y	WD	0422	1590		25,000
01/01/80	BETTS ARA A	Q	QUALIFIED	Y	WD	0410	0680		20,000
01/01/80	LUCAS JAMES B		INVALID CODE	N		----	----		

### PROPERTY APPRAISER INSPECTIONS

INSP. DATE	ROLL	EMPL	CODE	REASON
05/31/22	2022	197	14	DESKTOP REVIEW
12/19/18	2019	176	17	5 YEAR REVIEW
11/19/14	2015	176	1	BUILDING PERMIT
03/04/13	2013	176	1	BUILDING PERMIT
12/15/11	2012	176	1	BUILDING PERMIT
11/17/10	2011	176	1	BUILDING PERMIT

### PROPERTY APPRAISER NOTES

January 01 2013
ADD & WT, NO EC, FOR 2013