

# stewart title<sup>®</sup>

## Property Profile Report

4/21/2026

9508 W Como Circle, Wasilla, AK 99623

Purported owner of Record: Galina Atavin

**Prepared by:**

Erin Hodgson  
Stewart Title of Fairbanks  
714 Gaffney Rd  
Fairbanks, AK 99701  
(907) 456-3474  
[listingpackages@stewart.com](mailto:listingpackages@stewart.com)

**Prepared for:**

***Jennifer Gopez***

**Report Provided by:**

Stewart Title of Fairbanks  
714 Gaffney Rd  
Fairbanks, AK 99701  
(907) 456-3474  
[www.stewart.com/fairbanks](http://www.stewart.com/fairbanks)

- |  |  |
|--|--|
| <input checked="" type="checkbox"/> Tax Report   | <input checked="" type="checkbox"/> Plat Map                     |
| <input type="checkbox"/> BEES Certificate        | <input checked="" type="checkbox"/> No As-Built                  |
| <input type="checkbox"/> Summary of Bldg Insp    | <input type="checkbox"/> As-Built Attached                       |
| <input checked="" type="checkbox"/> Vesting Deed | <input type="checkbox"/> As-Built Requested/Will forward if rcvd |
| <input type="checkbox"/> Deed of Trust           | <input type="checkbox"/> Other                                   |
| <input checked="" type="checkbox"/> CC&R's       | <input type="checkbox"/> Notice of Default                       |

## Disclaimer

This property report is provided "as is" without warranty of any kind, either express or implied, including without limitations any warranties of merchantability or fitness for a particular purpose. There is no representation of warranty that this information is complete or free from error, and the provider does not assume, and expressly disclaims, any liability to any person or entity for loss or damage caused by errors or omissions in this property report without a title insurance policy.

The information contained in this property report is delivered from your Title Company, who reminds you that you have the right as a consumer to compare fees and serviced levels for Title, Escrow, and all other services associated with property ownership, and to select providers accordingly. Your home is the largest investment you will make in your lifetime and you should demand the very best.



# MATANUSKA-SUSITNA BOROUGH

## Real Property Detail for Account: 58674B02L006

**Site Information**

Account Number	58674B02L006	Subdivision	BELLA RDG PH 1
Parcel ID	547588	City	None
TRS	S17N02W17	Map HO10	Tax Map
Abbreviated Description (Not for Conveyance)	BELLA RDG PH 1 BLOCK 2 LOT 6		

Site Address: 9508 W Como Cir

Ownership

Owners: ATAVIN GALINA

Primary Owner's Address: PO BOX 875583 WASILLA AK 99687

Buyers

Primary Buyer's Address

**Appraisal Information**

Appraisal				Assessment			
Year	Land Appraised	Bldg. Appraised	Total Appraised	Year	Land Assessed	Bldg. Assessed	Total Assessed <sup>1</sup>
2026	\$40,300.00	\$0.00	\$40,300.00	2026	\$40,300.00	\$0.00	\$40,300.00

**Building Information**

**Building Item Details**

Building Number	Description	Area	Percent Complete
-----------------	-------------	------	------------------

**Tax/Billing Information**

Year	Certified	Zone	Mill	Tax Billed
2026	No	0038	::	::

**Recorded Documents**

Date	Type
3/27/2026	WARRANTY DEED (ALL TYPES)

**Recording Info (offsite link to DNR)**  
[Palmer 2026-005379-0](#)

**Tax Account Status <sup>2</sup>**

Status	Tax Balance	Farm	Disabled Veteran	Senior	Total <sup>3</sup>	LID Exists
			\$0.00	\$0.00	\$0.00	\$0.00 No

**Land and Miscellaneous**

Gross Acreage	Taxable Acreage	Assembly District	Precinct	Fire Service Area	Road Service Area
1.59	1.59	Assembly District 005	<u>26-360</u>	136 WEST LAKES FSA	027 Meadow Lakes RSA

<sup>1</sup> Total Assessed is net of exemptions and deferrals, rest, penalties, and other charges posted after Last Update Date are not reflected in balances.

<sup>2</sup> If account is in foreclosure, payment must be in certified funds.

<sup>3</sup> If you reside within the city limits of Palmer or Houston, your exemption amount may be different.

Last Updated: 4/21/2026 2:00:01 PM



File for Record at Request of:  
**First American Title Insurance Company**

AFTER RECORDING MAIL TO:

Name: **Galina Atavin**  
Address: **PO Box 875583**  
**Wasilla, AK 99687**  
File No.: **0281-4354197 (NC)**

---

#### STATUTORY WARRANTY DEED

THE GRANTOR, **Basis Alaska, LLC**, an Alaska limited liability company, whose mailing address is **3225 McLeod Drive Suite 100, Las Vegas, NV 89121**, for and in consideration of **TEN DOLLARS AND OTHER GOOD AND VALUABLE CONSIDERATION**, in hand paid, conveys and warrants to **Galina Atavin, a married woman**, residing at **PO Box 875583, Wasilla, AK 99687**, the following described real estate, situated in the **Palmer** Recording District, **Third** Judicial District, State of **Alaska**:

**Lot 6, Block 2, BELLA RIDGE PHASE 1, according to the official plat thereof, filed under Plat Number 2025-131, Records of the Palmer Recording District, Third Judicial District, State of Alaska.**

SUBJECT TO reservations, exceptions, easements, covenants, conditions and restrictions of record, if any.



**CERTIFICATE OF OWNERSHIP & DEDICATION**

WE CERTIFY THAT WE ARE THE OWNERS OF THE PROPERTY SHOWN AND DESCRIBED IN THIS PLAN AND THAT WE ADOPT THIS PLAN OF SUBDIVISION BY OUR FREE CONSENT, DEDICATE ALL RIGHTS-OF-WAY TO THE MATANUSKA-SUSITNA BOROUGH AND GRANT ALL EASEMENTS TO THE USE SHOWN.

A. Raan Oct. 2, 2025  
SIGNATURE DATE

Anita Raubeson Authorized signer

NAME/TITLE  
BASIS ALASKA, LLC  
3225 McLEOD DRIVE  
LAS VEGAS, NEVADA 89121

**NOTARY ACKNOWLEDGMENT**

SUBSCRIBED AND SWORN TO BEFORE ME THIS 2<sup>nd</sup> DAY OF October, 2025  
FOR Anita Raubeson

NOTARY FOR THE STATE OF ALASKA  
MY COMMISSION EXPIRES 11/15/28

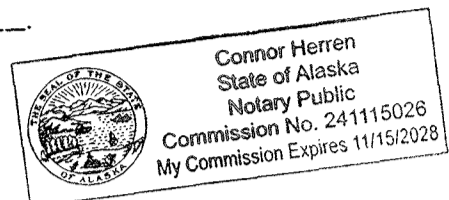

**BENEFICIARY**

Paul A. Dombroski 10-2-25  
SIGNATURE DATE

NAME/TITLE  
Paul A. Dombroski / AVP  
NORTHTRIM BANK  
WASILLA FINANCIAL CENTER  
P.O. BOX 241489  
ANCHORAGE, ALASKA 99524

**NOTARY ACKNOWLEDGMENT**

SUBSCRIBED AND SWORN TO BEFORE ME THIS 2<sup>nd</sup> DAY OF October, 2025  
FOR Paul A. Dombroski

NOTARY FOR THE STATE OF ALASKA  
MY COMMISSION EXPIRES 6/27/29

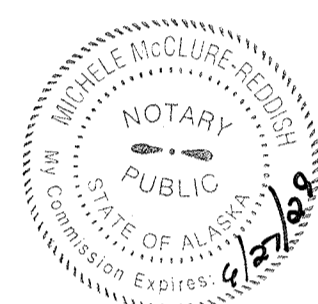

**LINE TABLE**

LINE	LENGTH	BEARING
L1	33.00'	N89°51'48"W
L2	25.63'	S89°51'42"E
L3	16.03'	S89°51'42"E
L4	12.10'	N89°53'15"E

**CURVE TABLE**

CURVE	LENGTH	RADIUS	TANGENT	DELTA	CHORD	CHORD BEARING
C1	47.01'	30.00'	29.89'	89°46'54"	42.35'	S44°58'15"E
C2	37.82'	50.00'	19.87'	43°20'30"	36.93'	N68°28'03"E
C3	80.99'	60.00'	48.02'	77°20'29"	74.98'	S85°28'02"W
C4	58.64'	60.00'	31.90'	56°00'00"	56.34'	N27°51'43"W
C5	58.64'	60.00'	31.90'	56°00'00"	56.34'	N27°51'43"W
C6	80.99'	60.00'	48.02'	77°20'32"	74.98'	S85°28'02"W
C7	37.82'	50.00'	19.87'	43°20'30"	36.93'	N68°28'03"E
C8	47.24'	30.00'	30.11'	90°13'06"	42.51'	S45°01'45"W
C9	47.24'	30.00'	30.00'	89°59'51"	42.43'	S45°06'50"E
C10	38.05'	200.00'	19.08'	10°54'03"	37.99'	N84°28'14"E
C11	54.95'	50.00'	30.62'	62°57'52"	52.22'	N47°30'16"E
C12	94.94'	60.00'	60.70'	90°39'47"	85.34'	S61°21'15"W
C13	77.09'	60.00'	44.90'	73°36'54"	71.90'	N36°30'25"W

**LEGEND**

- ✱ FOUND GENERAL LAND OFFICE BRASS CAP MONUMENT AS SHOWN AND DESCRIBED
- ⊕ FOUND 3-1/4" ALUMINUM CAP MONUMENT AS SHOWN AND DESCRIBED
- ⊙ SET 5/8" x 30" ALUMINUM CAP PIPE MONUMENT AS SHOWN AND DESCRIBED
- ⊙ FOUND 5/8" REBAR WITH PLASTIC CAP AS SHOWN AND DESCRIBED
- Δ SURVEY CONTROL POINT - SPC(5004 AK 4) NORTHING: 842,154.390 METERS EASTING: 516,329.753 METERS
- SET 5/8" x 30" REBAR WITH 1-1/4" SELF-IDENTIFYING PLASTIC CAP

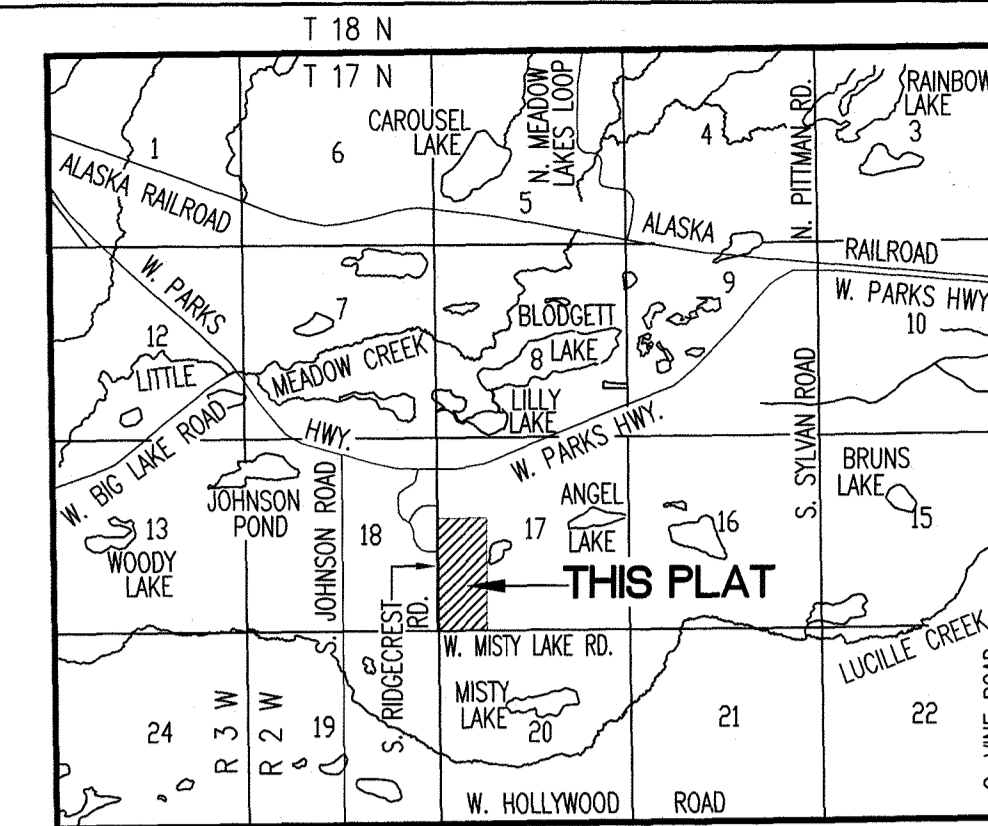

VICINITY MAP  
SCALE 1" = 1 MILE

**NOTES**

1. THERE MAY BE FEDERAL, STATE AND LOCAL REQUIREMENTS GOVERNING LAND USE. IT IS THE RESPONSIBILITY OF THE INDIVIDUAL PARCEL OWNER TO OBTAIN A DETERMINATION WHETHER SUCH REQUIREMENTS APPLY TO THE DEVELOPMENT OF PARCELS SHOWN HEREON.
2. BASIS OF BEARING FROM G.P.S. OBSERVATION TAKEN AT THE SURVEY CONTROL POINT SHOWN HEREON. TIE FROM SURVEY CONTROL POINT TO SECTION CORNER SHOWN HEREON: S01°07'59"E 2154.42'
3. 5/8" x 30" REBAR WITH 1-1/4" SELF-IDENTIFYING PLASTIC CAP SET AT ALL LOT CORNERS, P.C.'S, P.T.'S AND P.R.C.'S UNLESS NOTED.
4. NO INDIVIDUAL WATER SUPPLY SYSTEM OR SEWAGE DISPOSAL SYSTEM SHALL BE PERMITTED ON ANY LOT UNLESS SUCH SYSTEM IS LOCATED, CONSTRUCTED AND EQUIPPED IN ACCORDANCE WITH THE REQUIREMENTS, STANDARDS AND RECOMMENDATIONS OF THE STATE OF ALASKA, DEPARTMENT OF ENVIRONMENTAL CONSERVATION, WHICH GOVERN THOSE SYSTEMS.
5. EASEMENTS OF RECORD NOT PLOTTED HEREON:
  - a) MEA EASEMENT RECORDED OCTOBER 6, 1961 IN BOOK 39, PAGE 66
  - b) MEA EASEMENT RECORDED JULY 24, 2020 AT SERIAL #2020-017113-0.
  - c) MEA EASEMENT RECORDED JULY 24, 2020 AT SERIAL #2020-017114-0.
  - d) MEA EASEMENT RECORDED JULY 9, 2021 AT SERIAL #2021-020401-0.
  - e) MTA EASEMENT RECORDED MAY 9, 2025 AT SERIAL #2025-008018-0.
  - f) ENSTAR EASEMENT RECORDED MAY 22, 2025 AT SERIAL #2025-008910-0.
  - g) MEA EASEMENT RECORDED JULY 30, 2025 AT SERIAL #2025-013792-0.

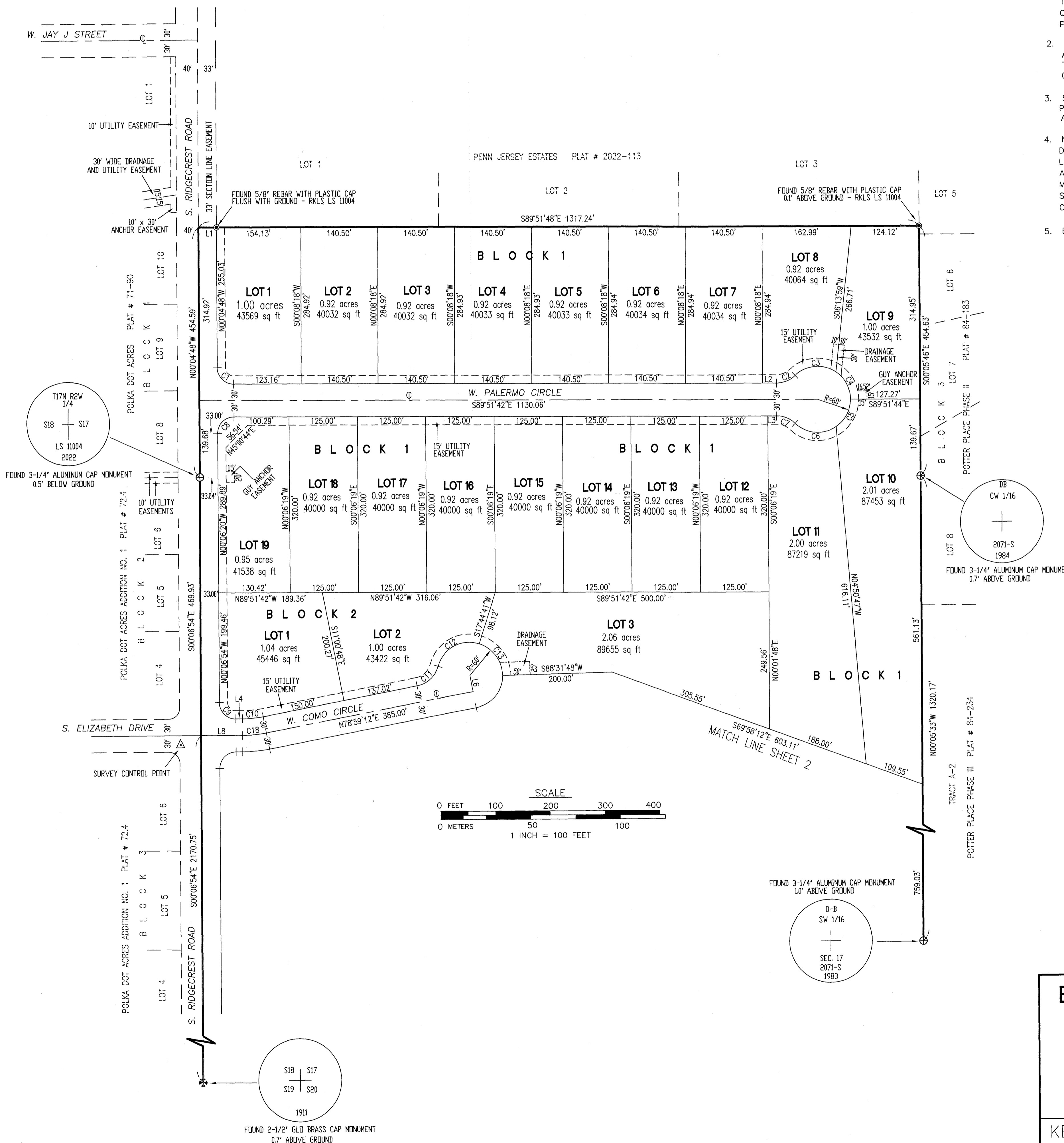

**PLANNING & LAND USE DIRECTOR'S CERTIFICATE**

I CERTIFY THAT THIS SUBDIVISION PLAN HAS BEEN FOUND TO COMPLY WITH THE LAND SUBDIVISION REGULATIONS OF THE MATANUSKA-SUSITNA BOROUGH, AND THAT THE PLAN HAS BEEN APPROVED BY THE PLATTING AUTHORITY BY PLAT RESOLUTION NO. 2025-093 DATED May 5, 2025. AND THAT THIS PLAT HAS BEEN APPROVED FOR RECORDING IN THE PALMER RECORDING DISTRICT, THIRD JUDICIAL DISTRICT, STATE OF ALASKA, IN WHICH THE PLAT IS LOCATED.

October 9, 2025 Annison  
DATE PLANNING & LAND USE DIRECTOR

ATTEST: [Signature]  
PLATTING CLERK



**CERTIFICATION OF PAYMENT OF TAXES**

I HEREBY CERTIFY THAT ALL CURRENT TAXES AND SPECIAL ASSESSMENTS, THROUGH December 31, 2025, AGAINST THE PROPERTY, INCLUDED IN THE SUBDIVISION OR RESUBDIVISION, HEREON HAVE BEEN PAID.

10/8/25 [Signature]  
DATE BOROUGH TAX COLLECTION OFFICIAL

**SURVEYOR'S CERTIFICATE**

I HEREBY CERTIFY THAT I AM A REGISTERED PROFESSIONAL LAND SURVEYOR IN THE STATE OF ALASKA AND THAT THIS PLAT REPRESENTS A SURVEY MADE BY ME OR UNDER MY DIRECT SUPERVISION, AND THAT THE MONUMENTS SHOWN ON THE PLAT ACTUALLY EXIST AS DESCRIBED, AND THAT ALL DIMENSIONAL AND OTHER DETAILS ARE TRUE AND CORRECT TO THE BEST OF MY KNOWLEDGE.

7330-S GARY LoRUSSO 09/23/25  
REGISTERED LAND SURVEYOR DATE

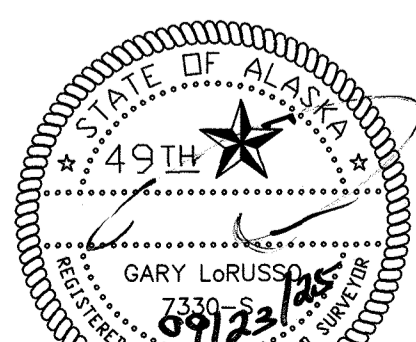

A PLAT OF  
**BELLA RIDGE PHASE 1**  
A SUBDIVISION OF LOT 4,  
PENN JERSEY ESTATES, PLAT #2022-113  
WITHIN THE  
W1/2 W1/2, SECTION 17, T. 17 N., R. 2 W.  
SEWARD MERIDIAN, ALASKA  
PALMER RECORDING DISTRICT  
THIRD JUDICIAL DISTRICT  
STATE OF ALASKA  
CONTAINING 93.58 ACRES, MORE OR LESS

**KEYSTONE SURVEYING & MAPPING**  
GARY LoRUSSO, PROFESSIONAL LAND SURVEYOR  
ALASKA BUSINESS LICENSE #134615  
MAILING ADDRESS: P.O. BOX 2216 • PALMER, ALASKA 99645  
PHYSICAL ADDRESS: 3635 N. VISTA CIRCLE • PALMER, ALASKA 99645  
PHONE: (907) 376-7811

DRAWN BY ICAD/K-Lyme	DATE 9/23/25	DRAWING: 2024-27/BellaRidgePh1
CHECKED BY Glo	SCALE 1 INCH = 100 FEET	SHEET 1 OF 2

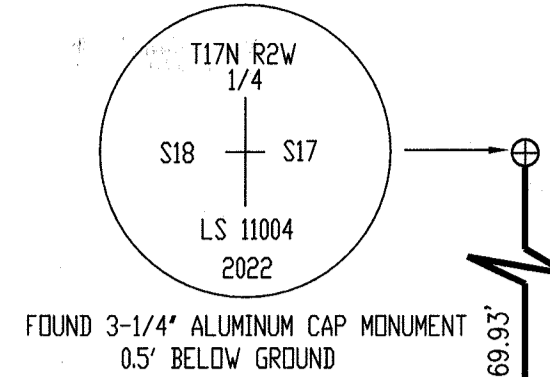

FOUND 3-1/4" ALUMINUM CAP MONUMENT  
0.5' BELOW GROUND

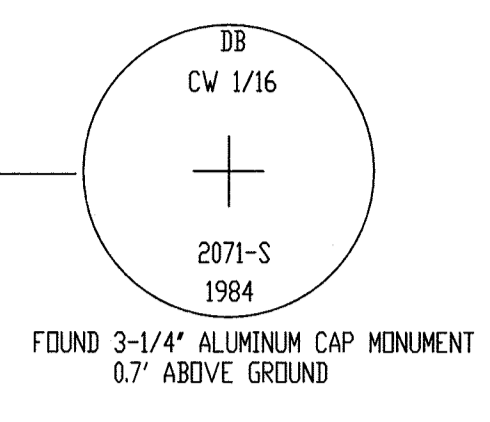

FOUND 3-1/4" ALUMINUM CAP MONUMENT  
0.7' ABOVE GROUND

LINE TABLE

LINE	LENGTH	BEARING
L5	12.10'	N89°53'15"E
L6	30.00'	N11°00'48"W
L7	37.46'	S78°41'40"E
L8	75.10'	N89°53'15"E
L9	33.00'	S00°07'20"E

CURVE TABLE

CURVE	LENGTH	RADIUS	TANGENT	DELTA	CHORD	CHORD BEARING
C14	46.08'	60.00'	24.24'	44°00'00"	44.95'	N22°18'02"E
C15	36.32'	60.00'	18.74'	34°41'10"	35.77'	N61°38'37"E
C16	49.47'	260.00'	24.81'	10°54'03"	49.39'	N84°26'14"E
C17	47.12'	30.00'	30.00'	89°59'32"	42.42'	S44°52'51"W
C18	43.76'	230.00'	21.95'	10°54'03"	43.69'	N84°26'14"E
C19	47.00'	30.00'	29.88'	89°46'19"	42.34'	S45°00'04"E

- LEGEND
- ⊕ FOUND GENERAL LAND OFFICE BRASS CAP MONUMENT AS SHOWN AND DESCRIBED
  - ⊕ FOUND 3-1/4" ALUMINUM CAP MONUMENT AS SHOWN AND DESCRIBED
  - ⊕ SET 5/8" x 30" ALUMINUM CAP PIPE MONUMENT AS SHOWN AND DESCRIBED
  - ⊕ FOUND 5/8" REBAR WITH PLASTIC CAP AS SHOWN AND DESCRIBED
  - △ SURVEY CONTROL POINT - SPC(5004 AK 4)  
NORTHING: 842,154.390 METERS  
EASTING: 516,329.753 METERS
  - SET 5/8" x 30" REBAR WITH 1-1/4" SELF-IDENTIFYING PLASTIC CAP

SURVEYOR'S CERTIFICATE

I HEREBY CERTIFY THAT I AM A REGISTERED PROFESSIONAL LAND SURVEYOR IN THE STATE OF ALASKA AND THAT THIS PLAT REPRESENTS A SURVEY MADE BY ME OR UNDER MY DIRECT SUPERVISION, AND THAT THE MONUMENTS SHOWN ON THE PLAT ACTUALLY EXIST AS DESCRIBED, AND THAT ALL DIMENSIONAL AND OTHER DETAILS ARE TRUE AND CORRECT TO THE BEST OF MY KNOWLEDGE.

7330-S GARY LoRUSSO  
REGISTERED LAND SURVEYOR

DATE: 09/23/25

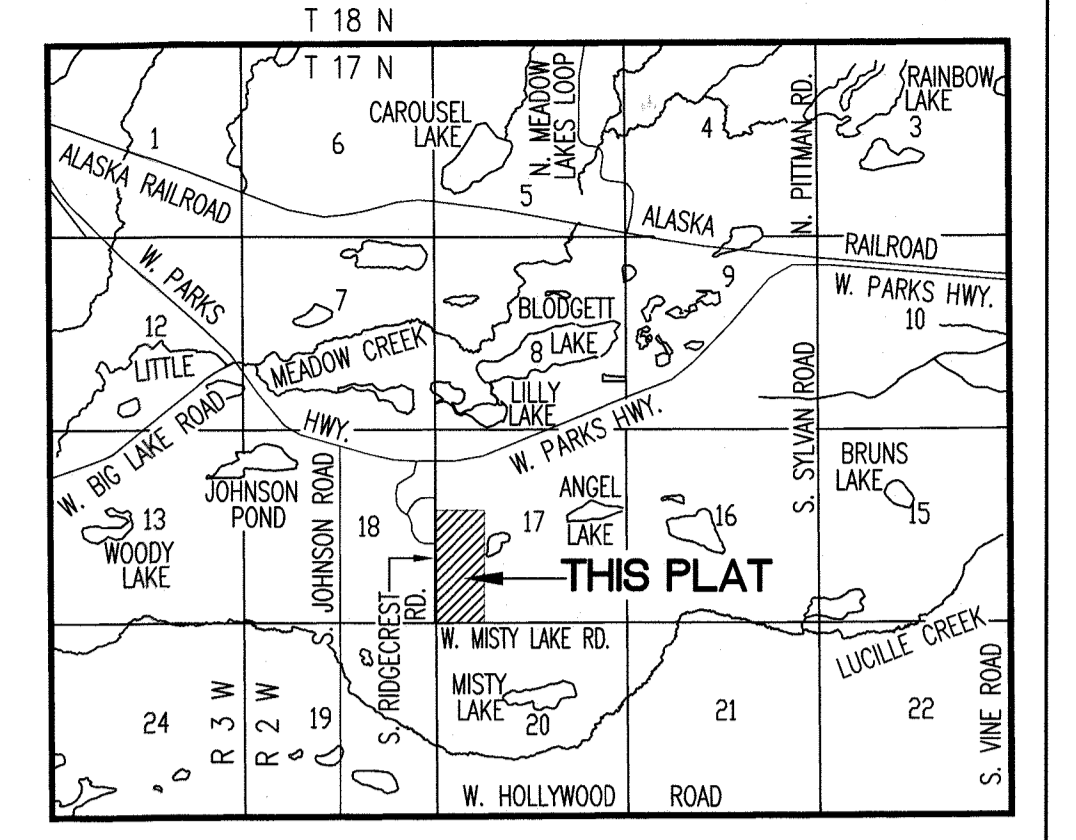

VICINITY MAP  
SCALE 1" = 1 MILE

- NOTES
- THERE MAY BE FEDERAL, STATE AND LOCAL REQUIREMENTS GOVERNING LAND USE. IT IS THE RESPONSIBILITY OF THE INDIVIDUAL PARCEL OWNER TO OBTAIN A DETERMINATION WHETHER SUCH REQUIREMENTS APPLY TO THE DEVELOPMENT OF PARCELS SHOWN HEREON.
  - BASIS OF BEARING FROM G.P.S. OBSERVATION TAKEN AT THE SURVEY CONTROL POINT SHOWN HEREON. TIE FROM SURVEY CONTROL POINT TO SECTION CORNER SHOWN HEREON: S01°07'59"E 2154.42'
  - 5/8" x 30" REBAR WITH 1-1/4" SELF-IDENTIFYING PLASTIC CAP SET AT ALL LOT CORNERS, P.C.'S, P.T.'S AND P.R.C.'S UNLESS NOTED.
  - NO INDIVIDUAL WATER SUPPLY SYSTEM OR SEWAGE DISPOSAL SYSTEM SHALL BE PERMITTED ON ANY LOT UNLESS SUCH SYSTEM IS LOCATED, CONSTRUCTED AND EQUIPPED IN ACCORDANCE WITH THE REQUIREMENTS, STANDARDS AND RECOMMENDATIONS OF THE STATE OF ALASKA, DEPARTMENT OF ENVIRONMENTAL CONSERVATION, WHICH GOVERN THOSE SYSTEMS.
  - EASEMENTS OF RECORD NOT PLOTTED HEREON:
    - MEA EASEMENT RECORDED OCTOBER 6, 1961 IN BOOK 39, PAGE 66
    - MEA EASEMENT RECORDED JULY 24, 2020 AT SERIAL #2020-017113-0.
    - MEA EASEMENT RECORDED JULY 24, 2020 AT SERIAL #2020-017114-0.
    - MEA EASEMENT RECORDED JULY 9, 2021 AT SERIAL #2021-020401-0.
    - MTA EASEMENT RECORDED MAY 9, 2025 AT SERIAL #2025-008018-0.
    - ENSTAR EASEMENT RECORDED MAY 22, 2025 AT SERIAL #2025-008910-0.
    - MEA EASEMENT RECORDED JULY 30, 2025 AT SERIAL #2025-013792-0.

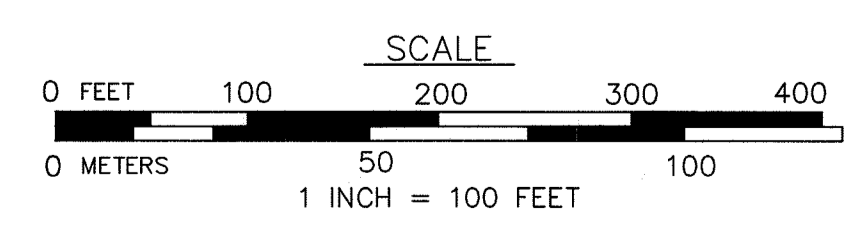
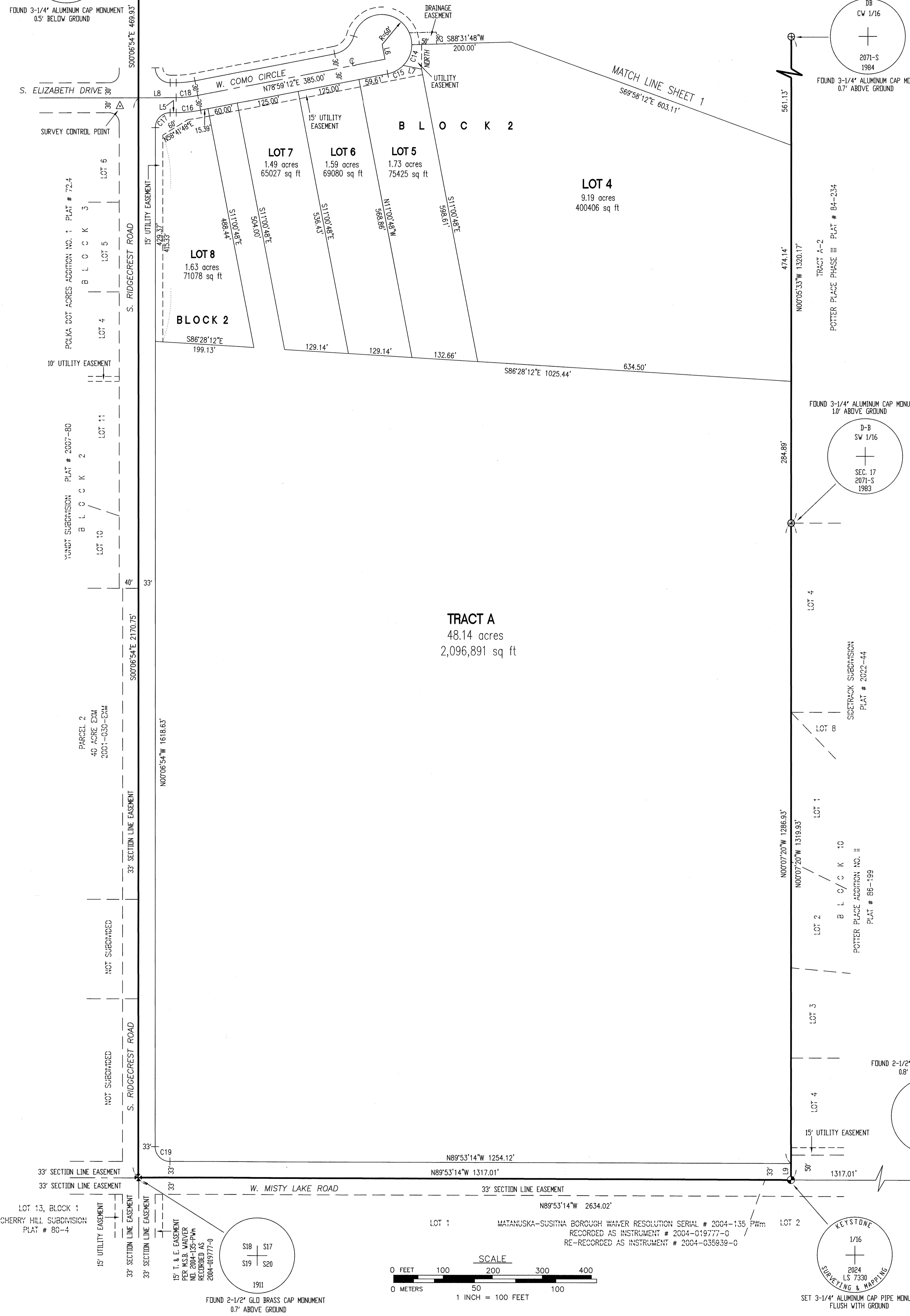

A PLAT OF

**BELLA RIDGE PHASE 1**

A SUBDIVISION OF LOT 4,  
PENN JERSEY ESTATES, PLAT #2022-113  
WITHIN THE  
W1/2 W1/2, SECTION 17, T. 17 N., R. 2 W.  
SEWARD MERIDIAN, ALASKA  
PALMER RECORDING DISTRICT  
THIRD JUDICIAL DISTRICT  
STATE OF ALASKA  
CONTAINING 93.58 ACRES, MORE OR LESS

**KEYSTONE SURVEYING & MAPPING**  
GARY LoRUSSO, PROFESSIONAL LAND SURVEYOR  
ALASKA BUSINESS LICENSE #134615  
MAILING ADDRESS: P.O. BOX 2216 • PALMER, ALASKA 99645  
PHYSICAL ADDRESS: 3635 N. VISTA CIRCLE • PALMER, ALASKA 99645  
PHONE: (907) 376-7811

2025-131  
Plat #  
Palmer  
Date: 9/23/25  
Time: 8:26 AM

DRAWN BY: ICAD/K.Lyne  
CHECKED BY: GLo

DATE: 9/23/25  
SCALE: 1 INCH = 100 FEET  
DRAWING: 2024-27/BellaRidgePh1  
SHEET 2 OF 2

This Instrument is being recorded by First American Title Co of AK as an accommodation only. It has not been examined as to its effect if any on the title of the estate herein.



## **Protective Covenants, Conditions and Restrictions for Bella Ridge Subdivision**

KNOW ALL MEN BY THESE PRESENTS,

THAT WHEREAS, the undersigned is the managing partner or authorized signer of BASIS ALASKA, LLC.

WHEREAS, that entity being the sole owner of properties comprising BELLA RIDGE SUBDIVISION.

WHEREAS, the undersigned desire to assure the continued development of BELLA RIDGE SUBDIVISION, on a high level for the benefit of future property owners and, for the protection of property values therein, do desire to place on and against certain real property within BELLA RIDGE SUBDIVISION, certain protective covenants regarding the improvements and/or use of the same;

NOW, THEREFORE, the undersigned do hereby establish and record the following declarations, reservations, protective covenants, limitations, conditions, restrictions and provisions regarding the use and/or improvements of all the property located in:

Bella Ridge Subdivision, Phases 1 and 2, according to Plat No. 2025-131, Document No. 2025-019651-0 Recorded in the Palmer Recording District, Third Judicial District, State of Alaska.

1. **PURPOSE.** That the purpose of these restrictions is to ensure the use of the property for attractive residential purposes is harmonious with the environment, to prevent nuisances, to maintain the desired tone of the community, and thereby to secure to each owner the full benefit and enjoyment of his home, with no greater restriction upon free and undisturbed use of his property than is necessary to ensure the same advantages to the other property owners.
2. **DEFINITIONS.**
  - “Environment” the surroundings or conditions in the geographical area of the subdivision.
  - “Architectural Control Committee (ACC)” group responsible for review and approval of building and site plans to maintain high aesthetics and protect property values of all lot owners. Initially comprised of a Basis Alaska LLC appointee.
  - “Lot” a single parcel of the plat described above.
  - “Dwelling” a single family house on a lot.
  - “Road” the roadbed, ditches and slopes within the borough right-of-way easement.
  - “Driveway” the improvement that provides vehicle access to and from a dwelling or structure.
  - “Subdivision” Bella Ridge Subdivision as more particularly described above
  - “Tract” the portion of the property which is described in the above mentioned plat as open space.
  - “Structure” means an outbuilding, garage, shed or shop not part of a dwelling and not used for housing, built on a foundation
3. **LAND USE.** All lots (excepting duplex lots as defined at end of paragraph) within the subdivision are hereby designed for construction and use of a single family dwelling only. No commercial use,

duplexes, triplexes, four-plexes or multi-family dwelling units shall be permitted. Mother-in-law apartments (either attached to the primary dwelling or a detached garage/shop) are permitted, provided they are not offered for rent other than to immediate family members of the residence owners. Lot 1 Block 1, Lot 19 Block 1 and Lot 1 Block 2 may be used for duplexes.

One detached garage/shed/shop will be allowed per lot, provided it is on a permanent foundation and completed to match the appearance, finish and quality of the primary residence, including matching colors and shingles. This detached outbuilding cannot exceed the primary residence in gross footage, and will adhere to other conditions pertaining to the primary residence such as setbacks, maximum heights, exterior appearance, and ACC approval. One additional matching outbuilding is permitted on either a permanent or non-permanent foundation not to exceed 14' x 24'. No outbuildings or shops are permitted in the front yard of any lot.

A lot may be used for an in-home office or business provided the following criteria are met: Traffic is not generated in excess of two additional vehicles per day on average. Equipment and operations do not create noise, dust, vibration, glare, fumes, odor, drainage, runoff, contamination, pollution, nuisance, or health hazard or are in violation of any governmental rules and regulations or nuisance that is objectionable to reasonable normal senses to adjacent lots.

No marijuana cultivation or retail is allowed on any lots. No mobile homes shall be permitted whatsoever, and travel trailers shall not be used for habitation beyond what is reasonable for housing house guests or during construction.

4. TREES. No owner shall allow any trees of size and beauty to be removed from their lot except as may be necessary to place improvements on the site. Any trees beyond the initial improvements shall be removed by hand so as to keep damage to surrounding trees to a minimum. The remaining stumps may be removed by heavy equipment.
5. DWELLINGS. All dwellings shall be built with a minimum of one thousand two hundred (1200) square feet of indoor living space, exclusive of any garage space, for single level residences. Two story residences shall have a minimum of sixteen hundred (1600) square feet, exclusive of garage space, of which at least eight hundred (800) square feet must be on the ground floor. These footages are exclusive of any below grade space. Each dwelling shall have a minimum of a 20' x 20' two car garage. Construction of the primary dwelling or any subsequent outbuildings must be completed within one year of ACC approval, except in the case where winter conditions prohibit paint which then must be completed before the end of June the following season.

Any building constructed on the property shall not exceed thirty five feet in height from ground plane outside the front door to the highest point on the ridgeline.

Exterior paint for initial construction shall be earth tones and approved by the ACC prior to its application. Subsequent repaints should be similar in shades and tones with the existing homes. No vinyl siding is allowed. No vertical grooved paneling (commonly known as T1-11) shall be used on any side of a dwelling visible from a road. Exterior architectural accents on the front aspects of the dwellings are required, ACC reserves the right to mandate additional architectural elements for aesthetics as a condition of approval.

30 days prior to commencement of construction of a primary dwelling or outbuilding an architectural plan and site plan must be submitted to the Architectural Control Committee for approval. After acknowledgment of receipt of application by ACC, in the absence of a written or emailed approval/disapproval the plans are considered approved. The initial Architectural



Control Committee shall be comprised of Basis Alaska Secretary and submittals sent to [basialaskallc@gmail.com](mailto:basialaskallc@gmail.com). At any time the ACC, through simple majority, may appoint or replace the Committee member(s) with a letter sent to all current property owners including notarized authorization and minutes of the meeting.

6. **ANIMALS.** No animals or livestock of any kind shall be raised, bred or kept on any lot or tract with the exception of dogs, cats, chickens or other normal indoor pets may be kept, provided that those pets are not kept, bred or maintained for any commercial purpose, and provided, further, that the total number of dogs and/or cats are kept on a premise does not exceed three (3) per dwelling. Up to six (6) shall permitted when subject owner has a fenced yard of over a quarter acre and pets do not cause nuisance. It is the owner's responsibility to ensure that the pets remain on the owner's property. Up to eight (8) chickens may be kept for personal use with no roosters being allowed. One animal enclosure in like material and appearance to main dwelling is permitted, but must be shielded from view of the street. NO dog breeding, boarding or sled dog teams are permitted.

Owners must maintain control of their pets, either through obedience training or physical restraint to ensure that the pets remain within the owner's lot and do not endanger other people or other domestic or wild animals within the subdivision. All animals adjudged nuisance, or in excess of allowable amount, by a simple majority of lot owners must be removed from the subdivision. For the purpose of these restrictions, horses are considered livestock.

7. **VEHICLE/FUEL STORAGE.** No lot or tract shall be used to park inoperable vehicles, and no ground storage of automobiles, save and except as the use of such lot as residence for the family requires and business vehicle as required for occupation. No vehicles shall be repaired or overhauled within the subdivision except within the confines of a private garage. Recreational vehicles, boats, trailers, travel trailers shall be kept behind the house or out of site of the road with the exception of one such type parked on the side of the garage.
8. **GARBAGE AND REFUSE DISPOSAL.** No lot or tract shall be used or maintained as a dumping ground for rubbish. Trash, garbage and other waste shall not be kept on the premises, in public view, and shall be disposed of in compliance with the ordinances set forth by the governmental body or bodies having jurisdiction thereof. Stacking of garbage bags in view of neighbors or the street is strictly forbidden, all trash bags should be kept in a trash can.
9. **TEMPORARY STRUCTURES.** No structure of a temporary character, motorhome, camper, trailer, tent, shack, garage, basement or other outbuilding erected on a lot shall be at any time used as a residence, either temporary or permanent, nor shall camping be permitted on any lot or tract or any other part of the subdivision.
10. **ACCESS TO LOTS.** Each lot is allowed no more than two driveways entering said lot, which driveway must be borough permitted and approved and must be perpendicular to the subdivision roads where possible. All driveway must be accessed from streets servicing Bella Ridge Subdivision. During snow removal, no lot owner shall push snow outside of their lot or onto or across neighborhood streets. All driveways must be paved, or topped with recycled asphalt product, inclusive of parking or driving areas extending on the side or behind the primary residence.
11. **SEWAGE SYSTEMS.** All on-site sewage disposal systems shall be constructed in accordance with the regulations set forth by the State of Alaska Department of Environmental Conservation. No sewer shall be placed within 100' of adjoining lots private water wells, nor shall any lot owner or contractor place sewers or wells in a way to preclude the ability to install sewers or wells on adjoining lots.



12. **SIGNS.** No signs of any kind shall be displayed to the public on any lot except one (1) sign not to exceed four (4) square feet, advertising the lot and improvement thereon for sale. This restriction, however, shall not apply to the developer of the subdivision. An American Flag is except from this rule. Political signs are strictly forbidden.
13. **RESUBDIVISION.** The lots herein described shall not be reduced in size by re-subdivision. However, owners of contiguous lots may combine and/or combine then redivide their lots, as may seem proper for them so long as the resulting lots are the same nominal size or larger and conform to the requirements of the Matanuska-Susitna Borough. The resulting lots shall then be treated for all purposes to these covenants as an enlarged single lot or in the case of moving lot lines as the same lots.
14. **DRAINAGE EASEMENTS.** The dedicated drainage easements referenced on the Plat are for the purposes of adequately draining and storing runoff to prevent erosion. No lot owner can use, alter or impede in anyway or direct or allow contractors or subcontractors under their direction to use, alter or impede in any way these drainage easements.
15. **EXTERNAL ANTENNAS.** No antenna, dish, or any other type of electronic device which has as its purpose the sending or receiving of signals to any external source of any kind shall be located on any part of any structure or lot subject to these covenants. Except, each lot owner may install on the exterior of the primary dwelling one standard television or one satellite dish. Ham radio towers and wind generators are specifically prohibited.
16. **REMOVAL OF VEGETATION AND LANDSCAPING REQUIREMENTS.** Upon completion of any lot improvements that require the removal of trees or regrading of soils, but not later than two years from occupancy of the dwelling, landscaping shall be implemented and completed on disturbed areas. All lots shall have final grading for drainage provided by the lot owner, his builder or agent prior to the last day of June following construction completion. Mitigation for runoff and erosion shall be provided for the duration of the projects or improvements, and any construction or disturbing of easements, slopes affecting roadways, easements or common elements, or common elements shall be restored and protected from erosion (with vegetation) as soon as possible.
17. **AMENDMENT.** At any time after these covenants are recorded, they may be amended, changed, modified, revoked or terminated, in whole or in part, by written agreement executed by a two third (2/3) majority of the owners of record of the 29 lots in the subdivision (20 lots) OR by the initial developer, Basis Alaska, LLC, provided it has written agreement of one additional property owner (one additional property may be under its ownership) OR by a simple majority of lot owners including the initial developer, Basis Alaska, LLC.
18. **WAIVER.** The failure by any lot owner or the developer to enforce any restrictions and/or covenant herein contained shall in no event be deemed as a waiver of the right to do so thereafter, as to the same breach, or as to one occurring prior to or subsequent to said breach, nor shall such failure give rise to any claim or cause of action against any lot owner or the developer.
19. **VIOLATION OF COVENANTS.** In the event of any violation or threatened violation of any of the restrictions and/or covenants herein contained, the developer or any owner of any lot in the subdivision, or their heirs, executors, administrators, successors or assigns may bring an action at law or in equity; either for injunction, action for damage or such other remedy as may be available. In the event judgment is recovered against any person for a violation or threatened violation of any of the restrictions and/or covenants herein contained, the party recovering such judgment shall also



be entitled to recover from such person reasonable attorney fees and costs of such action.

Violation of these restrictions and covenants, or any one of them, shall not defeat or render invalid the lien of any mortgage, deed of trust, or conditional sales contract made upon said lots subject thereto, now or hereafter of record.

20. SEVERABILITY. That invalidation of any of these restrictions and covenants by judgment or court order shall not affect any other provisions herein, which shall remain in full force and effect.

IN WITNESS WHEREOF, the undersigned have set their hands and seals.

Dated: Oct. 15 2025

[Signature]

STATE OF ALASKA )  
THIRD JUDICIAL DISTRICT )

The foregoing instrument was acknowledged before me on October 15, 2025 by  
Anita Raubeson, managing member  
Basis Alaska, LLC

Natasha Crothers  
NOTARY PUBLIC IN AND FOR ALASKA  
My commission expires: 5/23/27



After Recording Return to:

Basis Alaska, LLC  
3225 McLeod Dr #100  
Las Vegas, NV 89121

