

FOR SALE

Development Opportunity

WALMART OUTPARCELS

10096 Kenai Spur Hwy., Kenai, Alaska
Store #4474

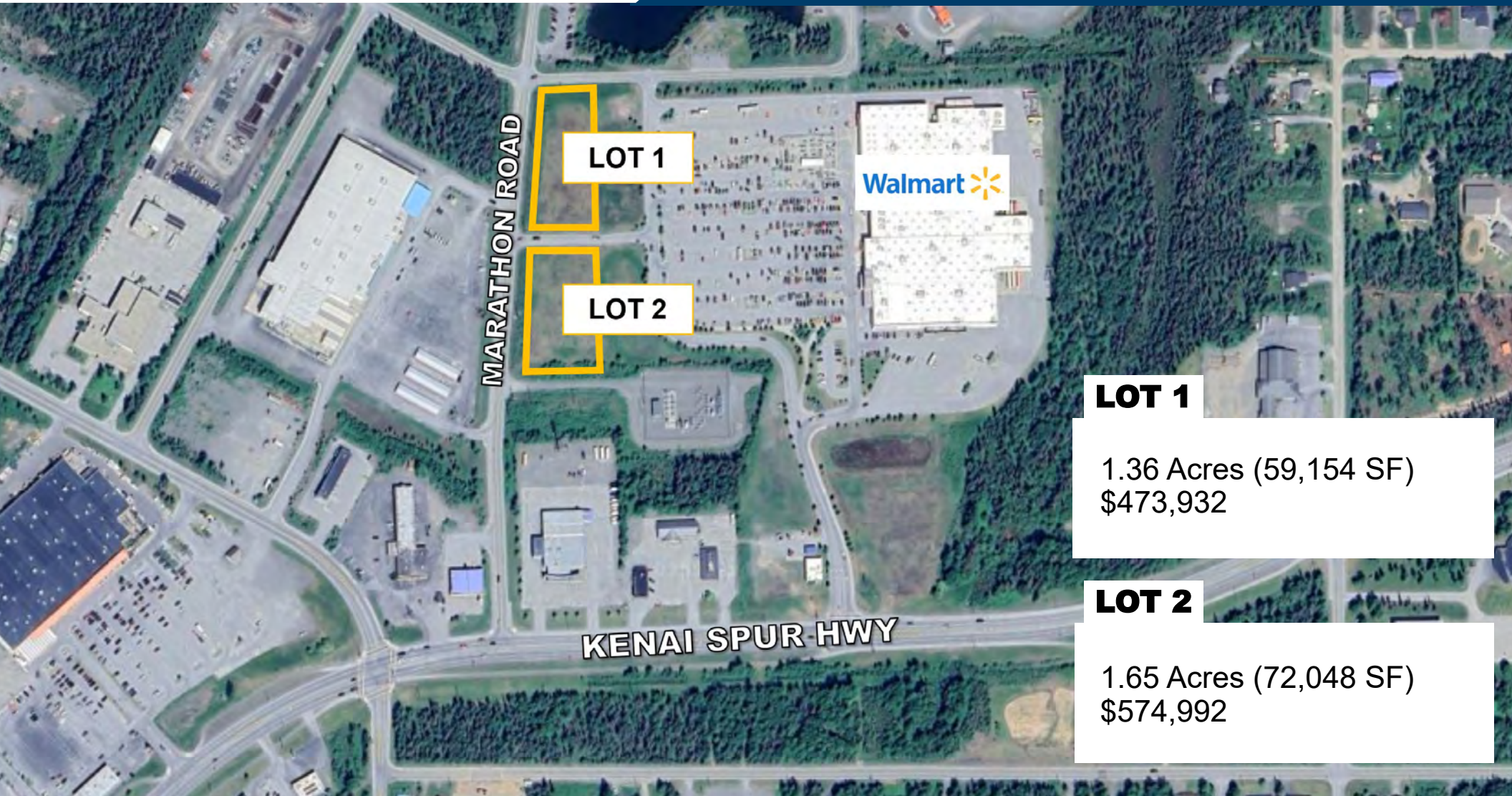

MARATHON ROAD

LOT 1

LOT 2

KENAI SPUR HWY

LOT 1

1.36 Acres (59,154 SF)
\$473,932

LOT 2

1.65 Acres (72,048 SF)
\$574,992

Jill Hall
907.301.2713
jill@cdkuhn.com

Carl D. Kuhn, CCIM, SIOR
907.301.1155
carl@cdkuhn.com



The Walmart outparcel lots are located on Marathon Road in Kenai, Alaska. They are adjacent to Walmart and in close proximity to Home Depot, Safeway, the Kenai Airport and a variety of smaller retailers and restaurants.

Lot 1 is approximately 1.36 acres, zoned light industrial and cleared of vegetation. Water and sewer are stubbed to the site, gas and electric are adjacent.

Lot 2 is approximately 1.65 acres, zoned light industrial and cleared of vegetation. Water and sewer are stubbed to the site, gas and electric are adjacent.

Both lots are in a highly visible location fronting Marathon Road and have easy access to the Kenai Spur Highway, which holds the highest traffic count in Kenai.



WALMART OUTPARCELS





Population	1 mile	3 miles	5 miles
2024 Total Population	583	6,816	11,288
2029 Total Population	596	7,067	11,753
2024-2029 Growth Rate: Population	0.4%	0.7%	0.8%
Household Income	1 mile	3 miles	5 miles
2024 Average Household Income	\$95,327	\$92,416	\$104,496



The city of Kenai is located in Southcentral Alaska at the mouth of the world famous Kenai River and is the hub of the Kenai Peninsula. The peninsula includes several of the most populous towns in Southcentral Alaska, including Seward, Soldotna, Sterling, Cooper Landing and Homer.

Kenai is a dynamic and rapidly developing community. The local economy thrives on oil & gas exploration and development along with commercial and sport fishing and tourism. Kenai is easily accessible from Anchorage via a 30-minute flight or a leisurely and beautiful 3-hour drive.

The Kenai Peninsula welcomes an average of 500,000 visitors annually. With a variety of fishing opportunities, the peninsula is the most well-known fishing destination in Alaska. The Kenai River itself is a world renowned salmon fishing destination. The Kenai Peninsula is also home to the Kenai Fjords National Park which offers unique Alaskan experiences from glacier viewing to whale watching.

Kenai's ideal location, natural recreation and strong economic opportunities have proven the city as the Heart of the Kenai Peninsula.

[PLAT No. 2006-56]
BARON PARK
KENAI YOUTH
ADDITION
 TRACT A

FIRE ADDITION
BARON PARK SUBDIVISION
 [PLAT No. 97-55]
 LEASE PORTION OF
 TRACT A-1-B
 TRACT A-1-B

MONUMENT DETAILS

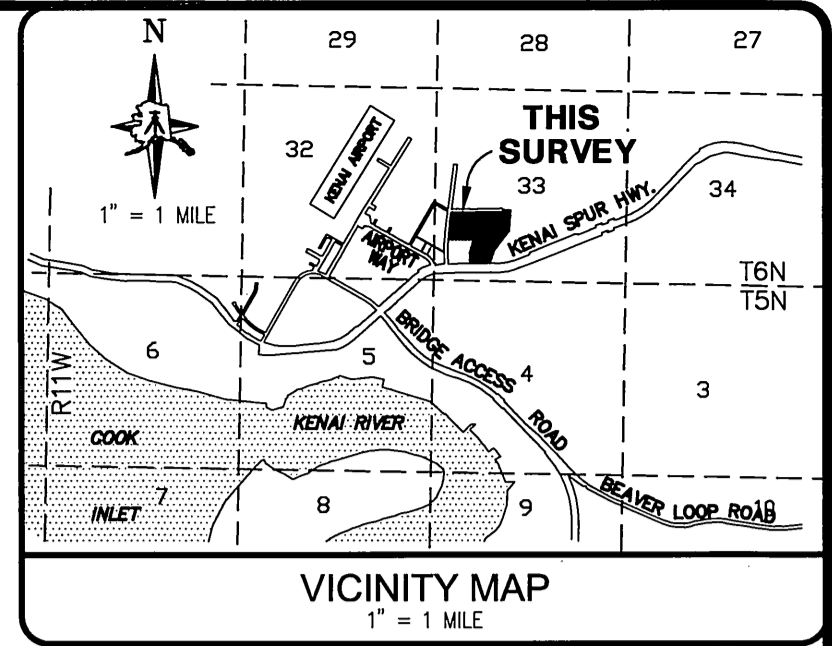
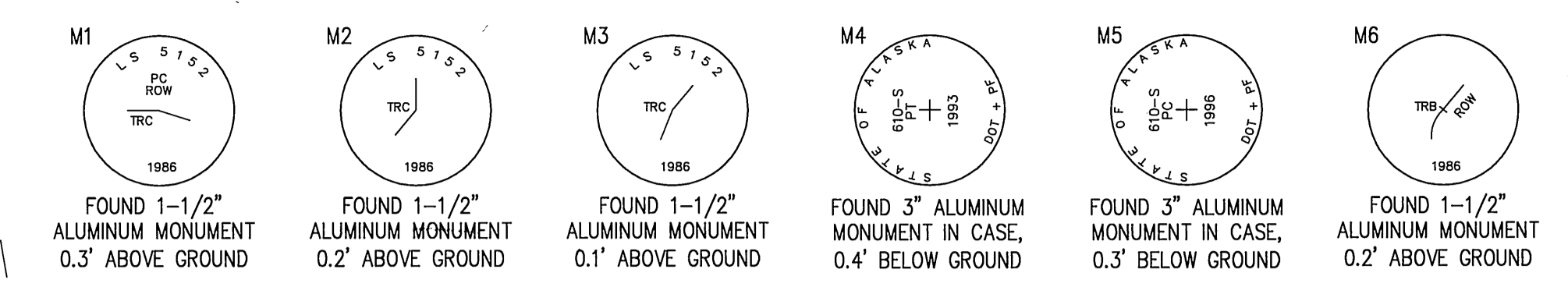

LINE DATA

LINE	BEARING	LENGTH	LINE
L1	S 73°45'08" E	88.32'	L1
L2	S 12°43'36" E	53.98'	L2
L3	S 02°05'03" E	72.36'	L3
L4	N 02°05'03" W	51.00'	L4
L5	S 87°53'40" W	51.00'	L5
L6	N 02°05'03" W	21.32'	L6
L7	N 12°43'36" W	58.12'	L7
L8	N 18°18'10" W	136.84'	L8
L9	N 16°13'40" E	49.37'	L9
L10	N 87°56'47" E	1.77'	L10

NOTES

- EASEMENTS OF RECORD, IF ANY EXIST, OTHER THAN THOSE SHOWN IN THE CERTIFICATE OF PLAT PREPARED BY STEWART TITLE OF THE KENAI PENINSULA, INC., FILE NO. 11275, DATED JANUARY 14, 2008, OR THE PLAT OF RECORD, NO. 2006-65, KENAI RECORDING DISTRICT, ARE NOT SHOWN HEREON.
- TOTAL AREA OF PARCELS BASED ON MEASURED DATA IS 1,665,949 SQUARE FEET OR 38.245 ACRES.
- RESERVATIONS AND EXCEPTIONS EXIST AS CONTAINED IN U.S. PATENT, AND/OR ACTS AUTHORIZING THE ISSUANCE THEREOF.
- RESERVATIONS AND EXCEPTIONS EXIST, AS CONTAINED IN THE QUIT CLAIM DEED FROM THE UNITED STATES OF AMERICA TO THE CITY OF KENAI, IN BOOK 27 AT PAGE 303, AND IN THE DEED OF RELEASE IN BOOK 311 AT PAGE 648 & BOOK 433 AT PAGE 194, AND IN THE NOTICE OF DEED RELEASE FOUND IN BOOK 402 AT PAGE 493.
- AN OIL & GAS LEASE, GRANTED BY THE STATE OF ALASKA DEPARTMENT OF NATURAL RESOURCES, MENTAL HEALTH OFFICE IN FAVOR OF THE UNION OIL COMPANY OF CALIFORNIA EXISTS IN DOCUMENT SERIAL NO. 2005-000723-0.
- EASEMENTS, SETBACKS, DEDICATIONS AND NOTES PERTAINING TO THE PLATTED PROPERTY EXIST PER PLAT No. 2006-65. SEE AFOREMENTIONED PLAT FOR MORE INFORMATION.
- UTILITY EASEMENT IN FAVOR OF HOMER ELECTRIC ASSOCIATION, INC. EXISTS IN BOOK 521, AT PAGE 276.
- PROPERTY IS SUBJECT TO A HIGHWAY RESERVATION 150 FEET ON EACH SIDE OF THE CENTER LINE THE KENAI SPUR HIGHWAY AS CLAIMED BY THE STATE OF ALASKA, OR ITS SUCCESSOR IN INTEREST, PURSUANT PUBLIC LAND ORDERS 601, 757, AND 1613 AND DEPARTMENT ORDER 2665 ISSUED BY THE SECRETARY OF INTERIOR OF THE UNITED STATES OF AMERICA.

NOTE:
 LOCATION OF HIGHWAY RESERVATION IS APPROXIMATE, THE CENTERLINE OF WHICH IS BASED ON A DRAWING BY THE ALASKA ROAD COMMISSION FROM 1947-1948, OF MILE 0.0 THROUGH 10.0 OF THE "KENAI SPUR RUSSIAN RIVER - HOMER ROAD" THAT CAN BE FOUND ON FILE AT THE ANCHORAGE OFFICE OF THE AKDOT & PF.

PLEASE NOTE THAT THE PROJECT AREA WAS LOCATED BETWEEN MILE MARKER 0.0 & 1.0 AS SHOWN IN THE 1947-1948 DRAWING. AT THE TIME OF OUR SURVEY, ACCORDING TO THE HIGHWAY LOG REPORT PROVIDED BY THE AKDOT & PF AND PROJECT "F-022-1(6)", THE PROJECT AREA IS LOCATED BETWEEN MILE MARKER 9.8 & 10.3.

- NO ACCESS TO STATE MAINTAINED RIGHT-OF-WAYS PERMITTED UNLESS APPROVED BY THE STATE OF AKDOT & PF.
- WASTEWATER DISPOSAL: PLANS FOR WASTEWATER DISPOSAL, THAT MEET REGULATORY REQUIREMENTS ARE ON FILE AT THE DEPARTMENT OF ENVIRONMENTAL CONSERVATION.
- NO PERMANENT STRUCTURE SHALL BE CONSTRUCTED OR PLACED WITHIN A UTILITY EASEMENT WHICH WOULD INTERFERE WITH THE ABILITY OF A UTILITY TO USE THE EASEMENT.
- WETLANDS MAPPED BY SHANNON & WILSON IN JUNE OF 2006, AND ARE AS SHOWN ON PLAT No. 2006-65, BARON PARK 2005 REPLAT.

LEGEND

- N 89°40'41" E 1241.57'
- N 89°40'34" E 1321.70'
- S 88°56'16" W 1136.56'
- (N 02°08'31" W 200.35')
- (N 87°50'53" E 320.44')
- * FOUND MONUMENT
- ⊕ FOUND ALUMINUM CAP
- FOUND REBAR
- × COMPUTED POINT, NOTHING SET
- SET 1-1/2" PLASTIC CAP ON 5/8"x30" REBAR, WITH TYPICAL MARKINGS:
- △ SEE CORRESPONDING NOTE UNDER NOTES
- AKDOT & PF ALASKA DEPARTMENT OF TRANSPORTATION & PUBLIC FACILITIES
- RO POINT ESTABLISHED BY RECORD OFFSET
- BI POINT ESTABLISHED BY BEARING INTERSECTION
- GA POINT ESTABLISHED BY GRANT ADJUSTMENT
- RD RECORD DISTANCE HELD TO ESTABLISH POINT
- DD POINT ESTABLISHED BY DISTANCE-DISTANCE INTERSECTION

CERTIFICATE OF OWNERSHIP AND DEDICATION

I HEREBY CERTIFY THAT WE ARE THE OWNERS OF THE REAL PROPERTY SHOWN AND DESCRIBED HEREON AND THAT WE HEREBY ADOPT THIS PLAN OF SUBDIVISION AND BY OUR FREE CONSENT DEDICATE ALL RIGHTS-OF-WAY TO PUBLIC USE AND GRANT ALL EASEMENTS TO THE USE SHOWN.

BY: Rick R. Koch FOR: CITY OF KENAI
 RICK R. KOCH, CITY MANAGER 210 FIDALGO AVE.
 CITY OF KENAI KENAI, ALASKA 99611

NOTARY'S ACKNOWLEDGMENT

Rick R. Koch PERSONALLY APPEARED SUBSCRIBED AND SWORN TO BEFORE ME THIS 8th DAY OF April, 2008.

Kim Howard
 NOTARY PUBLIC FOR ALASKA
 7/10/2008
 MY COMMISSION EXPIRES

PLAT APPROVAL

THIS PLAT WAS APPROVED BY THE KENAI PENINSULA BOROUGH PLANNING COMMISSION AT THE MEETING OF January 14, 2008
 KENAI PENINSULA BOROUGH:
 BY: Maureen
 AUTHORIZED OFFICIAL

PLAT OF
BARON PARK 2008 REPLAT
 CREATING: TRACT 1A & LOTS 1-4
 A SUBDIVISION OF
 TRACT 1, BARON PARK 2005 REPLAT (PER PLAT No. 2006-65)
 LOCATED WITHIN
 SW¼ OF SECTION 33, T6N, R11W, SEWARD MERIDIAN,
 CITY OF KENAI, KENAI PENINSULA BOROUGH,
 KENAI RECORDING DISTRICT, THIRD JUDICIAL DISTRICT, STATE OF ALASKA.
 CONTAINING: 38.245 ACRES

2008-32
 KENAI REC DIST
 Date 5-5-2008
 Time 2:10 P.M.
 Requested By Stewart
 Address

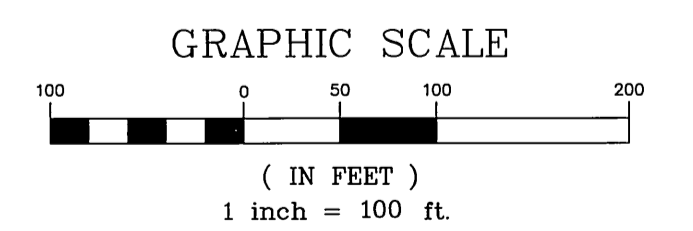
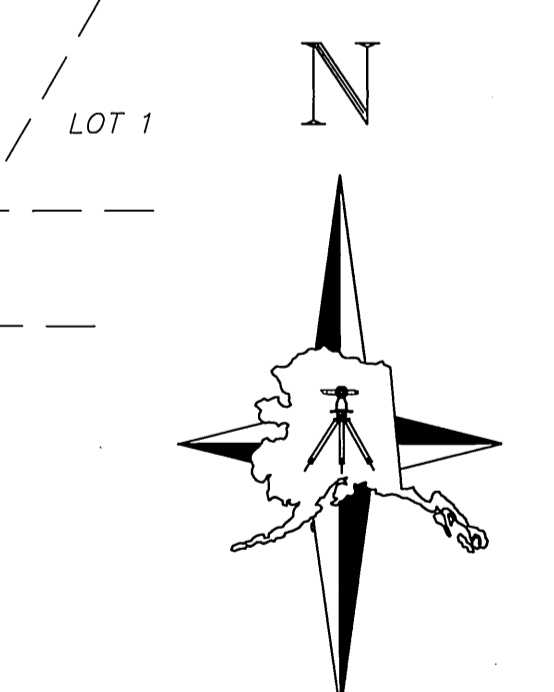

CURVE DATA

CURVE	RADIUS	LENGTH	TANGENT	CHORD	BEARING	DELTA
C1	230.00'	73.32'	36.97'	73.01'	S 06°54'42" W	181°5'53"
(C1)	230.00'	73.68'				
C2	50.00'	110.72'	100.01'	89.45'	N 61°49'28" E	126°52'34"
(C2)	50.00'	110.71'				
C3	512.00'	50.17'	25.11'	50.15'	S 15°29'43" E	5°36'53"
C4	371.00'	68.91'	34.56'	68.81'	N 07°24'20" W	10°38'33"
C5	456.00'	84.70'	42.47'	84.58'	N 07°24'20" W	10°38'33"
C6	169.98'	41.10'	20.65'	41.00'	N 09°17'58" E	13°51'14"

SURVEYOR'S CERTIFICATE

I, KENNETH W. AYERS, PROFESSIONAL LAND SURVEYOR DO HEREBY CERTIFY THAT THE PLAT OF TRACT 1A & LOTS 1-4, BARON PARK 2008 REPLAT, IS A TRUE AND CORRECT REPRESENTATION OF LANDS ACTUALLY SURVEYED AND THAT ALL THE DISTANCES AND BEARINGS ARE SHOWN CORRECTLY AND THAT ALL PERMANENT EXTERIOR CONTROL MONUMENTS, AND ALL OTHER MONUMENTS HAVE BEEN SET AND STAKED.

4/10/08 Kenneth W. Ayers
 DATE SIGNATURE OF LAND SURVEYOR

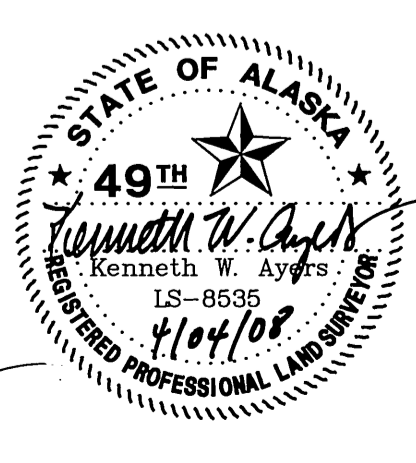

STATE OF ALASKA
 610-S
 T6N R11W
 S 32-1/4 S 33
 S 1-1/4 S 34
 115W
 1996
 507 = 91'
 FOUND 3-1/4" ALUMINUM MONUMENT 0.2' BELOW GROUND IN CASE

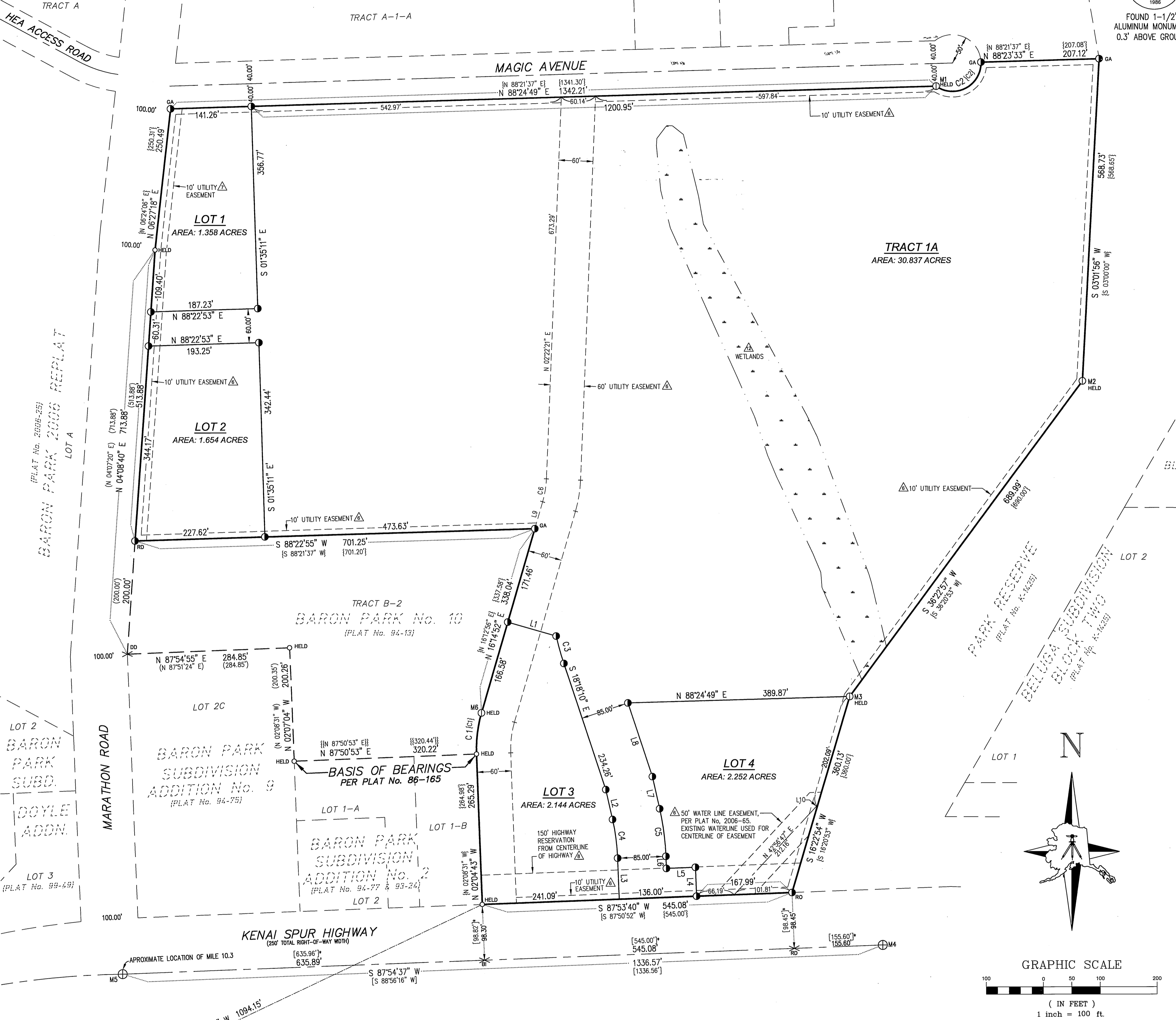

PORTION OF THE SW¼ SW¼ SW¼, SECTION 33
 (ALASKA DEPARTMENT OF TRANSPORTATION PROJECT No. F-022-1(6))

Lounsbury & Associates, INC

3161 E. Palmer-Wasilla HWY, #2
Wasilla, Alaska 99654

Tom Adams
(907) 357-9129
(907) 357-9140

t.adams@lounsburyInc.com

Location of Project: **Kenai, Alaska**

Store Type: **Supercenter**

Size of the Store: **210,799** Store #: **4474**

Date of this Report: **Friday, August 28, 2009**

<u>OUTLOT/EXCESS LAND</u>			<u>SETBACKS</u>				<u>ZONING</u>
			Minimum building setbacks for each property				Current zoning
Lot #	Size (in Acres)	Square footage	Front	Left Side	Right Side	Back	Zoning
Lot 1	1.36 AC	59,154					Light Industrial (IL)
Lot 2	1.65 AC	72,048					Light Industrial (IL)
Lot 3	2.14 AC	93,393					Light Industrial (IL)
Lot 4	2.25 AC	98,097					Light Industrial (IL)

ZONING

1. Is there an Overlay District, PUD, etc. that impacts the development of the outlot/excess land?

No

2. If yes, please describe:

3. What Jurisdiction is the property in?

City of Kenai

4. Is a restaurant permitted?

Yes

5. Is patio seating permitted?

Yes

6. Is there a restriction prohibiting a drive thru (restaurant, bank, etc.)?

No

7. Please add any additional information/comments that impact the outlot/excess land regarding zoning:

PARKING REQUIREMENTS:

1. Wal-Mart's required parking ratio:

Restaurant	15 / 1,000
Retail	5 / 1,000

2. Is the City or County's parking requirement greater than Wal-Mart's

No

If Yes, what is the requirement?

Restaurant	
Retail	

SIGNAGE:

1. What type of signage is allowed for the outlots per local codes and/or ordinances?

Other

2. If other, please define:

Freestanding or marquee

3. What is the maximum height allowed for the signage?

Thirty two (32) feet. (KMC 14.20.220)

4. What is the maximum square footage allowed for the signage?

One (1) freestanding or marquee per premises of not more than one hundred twenty (120) square feet. Where there is more than one (1) business on a premises a combined freestanding or marquee sign of not more than two hundred (200) square feet. (KMC 14.20.220)

5. Explain how the square footage is calculated:

The Building Official shall determine the area of all signs and shall classify all signs. (KMC 14.20.220)

6. If Other or No signage is permitted explain why and give options to change the signage regulations:

7. Is roof signage permitted?

Yes

8. What is the maximum size?

64 square feet (KMC 14.20.220); no roof sign shall be higher than eight feet (8') above the roof on which it is located.

9. Are wall logo's and/or signs permitted?

Yes

10. Is Neon signage permitted?

Select Yes/No

11. How long is the variance process for outlot signage and what is required?

An application for a variance permit shall be filed in writing with the administrative official and signed by the owner of the property concerned. Plans showing the location of all existing and proposed buildings or alterations, elevations of such buildings or alterations, and such data as may be required; a nonrefundable deposit/advertising fee of one hundred dollars (\$100.00). Requires Public Hearing.

12. Describe all reviews, hearings, variances and general requirements known at this time:

None

PLATTING

1. Is the property (including the outlots/excess land) required to be platted?

Yes

1a. If no please explain:

1b. If yes, has the plat been recorded?

Yes

1c. What is the book, page or volume?

Plat No. 2008-32, Kenai Recording District

1d. What was the date it was recorded?

5-May-08

2. If the property has not been platted, please describe the process including who is responsible for the platting and timeframe for completion.

****Note: If platting is not required, a metes and bounds legal description for each parcel should be forwarded to the respective Wal-Mart Land Development Manager as soon as possible.**

STREET/HIGHWAY ACCESS AND TRAFFIC STUDY:

1. Who has Jurisdiction on this site?

City of Kenai (Lots 1&2), ADOT&PF (Lots 3&4)

2. Will the Jurisdiction allow direct access and/or curbcuts to the main street or highway?

No

3. If there is a concrete median in front of the property, will the Jurisdiction allow it to be cut?

Select Yes/No

****Note: Wal-Mart does not typically allow purchaser's direct access and/or curbcuts to the main street or highway. Access to the outlot/excess land is granted through the Wal-Mart access drive!**

4. Are there any future highway/street improvements anticipated that would impact the outlot/excess land?

No

4a. If yes, please describe along with the timeframe and location:

5. Are sidewalks required on the outlot/excess land?

No

5a. If yes, what type and size:

6. Was a traffic study performed for the overall project?

Yes

6a. If yes, was the outlot(s)/excess land included?

Yes

6b. What was the estimated traffic count, peak hour trips, total trips, proposed use, etc. for each parcel?

Estimated peak hour trips ranged between forty (40) and one hundred (100) for the anticipated uses.

6c. Will an additional traffic study be required for each purchaser? No

6d. If yes, please explain why and any requirements including applicable timeframes:

6e. Does the traffic study, trips, etc. have an expiration date? No

6f. If yes, please provide the expiration date and any other important information:

UTILITIES:

Water

- 1. Is water stubbed to the outlot(s)? Yes
 1a. If not, where is it located? *Lot 1 & 2 stubbed; Lot 3&4 along highway frontag*
- 2. Is water stubbed to the excess land? Select One
 2a. If not, where is it located?
- 3. Who has Jurisdiction of the water line? *City of Kenai*
- 4. What is the size of the water main? *8" (Lots 1/2); 12" (Lots 3/4)*
- 5. What is the normal pressure? *80 psig*
- 6. Is there a Tap Fee? Yes
- 7. Is there a Meter Fee? No
- 8. Can the hose bibs & irrigation be on a separate meter? No
- 9. What is the size of the line required?
- 10. Are backflow preventer valves required for fire sprinkler lines? Yes
- 11. Is the water line located in an existing easement? No
- 12. Is there a current moratorium or a chance for one in the future? No
- 13. Please add any additional information/comments regarding water:

Sanitary Sewer

- 1. Is sanitary sewer stubbed to the outlot(s)? Yes
 1a. If not, where is it located? *Lot 1 & 2 stubbed; Lot 3&4 along highway frontag*
- 2. Is sanitary sewer stubbed to the excess land? Select One
 2a. If not, where is it located?
- 3. What is the size of the sewer line? *Eight (8) inch*
- 4. Who has the Jurisdiction of the sanitary sewer line? *City of Kenai*

5. Nearest manhole:	Lot 1	Rim El.		Inv.El.Out	
	Lot 2	Rim El.		Inv.El.Out	
	Lot 3	Rim El.		Inv.El.Out	
	Lot 4	Rim El.		Inv.El.Out	

- 6. Is a grease trap required for a restaurant?
- 7. Is there a Tap Fee?
- 8. Are tap fees based on water useage?
- 9. Is the tap to be made by the city or a local plumber?
- 10. Are there any special assessments?
- 11. Is there a current moratorium or a chance for one in the future?
- 12. Is the sanitary sewer line located in an existing easement?
- 13. If sanitary sewer is not available, can a septic system be used?

13a. What type?

13b. Additional Comments:

14. Can the septic field be paved over?

15. Has a percolation test been performed?

15a. When?

15b. What were the results? (1' in 30 minutes is required for a restaurant)

15c. If the test did not meet the above requirements, what are the alternative solutions?

****Note: Purchaser is responsible to perform their own percolation test on the outlot/excess land if a septic system is required.**

16. Please add any additional information/comments regarding sanitary sewer:

Storm Sewer:

1. Is storm sewer stubbed to the outlot?

2. Is storm sewer stubbed to the excess land?

3. If not, please explain how the storm sewer drainage will be addressed for each outlot/excess land:

- 4. Has Wal-Mart's detention facility been sized to accept the drainage? No
- 5. Is the Wal-Mart detention pond encroaching on or included within the outlot/excess land property line? No
- 6. Who has the Jurisdiction of the storm sewer? [Empty Box]
- 7. What is the size of the storm sewer? [Empty Box]
- 8. What is the depth? [Empty Box]
- 9. What is the tap fee? [Empty Box]
- 10. Are catch basins required? Select Yes/No
- 11. Is the storm sewer located in an existing easement? Select Yes/No

12. Please add any additional information/comments regarding storm sewer:
Storm drain not available.

****Note: Purchaser will have to comply fully with any federal, state or local laws, regulations, ordinances, permits or other authorizations or approvals or other requirements relating to storm water discharges or the control or erosion or sediment discharges from construction projects, including but not limited to the Clean Water Act, 33 U.S.C.-1251 et seq., and the Storm Water General Permit for Discharges associated with Construction Activities (collectively the "Storm Water Requirements") including without limitation preparing a Storm Water Pollution Prevention Plan (if applicable) to avoid negatively impacting any erosion or sediment controls during earth-disturbing activities, if any.**

Electric

- 1. Is electric stubbed to the outlot? No
 - 1a. If not, where is it located? Street frontage
- 2. Is electric stubbed to the excess land? Select One
 - 2a. If not, where is it located? [Empty Box]
- 3. Is it overhead or underground? Underground
- 4. What is the voltage? [Empty Box]
- 5. What is the phase? [Empty Box]
- 6. What is the wire? [Empty Box]
- 7. Who has Jurisdiction of the electricity? Homer Electric Association
- 8. Is underground service required? No
 - 8a. If yes, will the power company bring conduit and wire to the transformer and/or building? Select Yes/No
- 8b. Is there a standard cost per LF for the installation? [Empty Box]
- 8c. Transformer location: [Empty Box]
- 8d. Can the outlot/excess land be serviced with either a pole mounted or pad mounted transformer? Select One
- 9. Is the primary service connected to the existing transformer? Select One
 - 9a. Are there any service charges or connection fees? Select One
 - 9b. What is the cost? [Empty Box]

10. Is the electric located in an existing easement?

11. Please add any additional information/comments regarding electric:
Developer should contact Utility Company (HEA) for service application.

Gas

1. Is gas stubbed to the outlot?
 1a. If not, where is it located? *adjacent ROW*

2. Is gas stubbed to the excess land?
 2a. If not, where is it located?

3. What is the maximum amount available?

4. Who has Jurisdiction of the gas line? *Enstar Natural Gas Company*

5. What type of commitment will the gas company give?

6. Will the gas company bring the line to the building?
 6a. What is the estimated cost to do so? *\$12/lf*
 6b. What is the size of the gas line?
 6c. What is the pressure of the gas line?
 6d. What is the BTU/CF rating?
 6e. What is the specific gravity?
 6f. Is a meter fee required?

7. Is the gas located in an existing easement?

8. Please add any additional information/comments regarding gas:

Telephone

1. Is telephone stubbed to the outlot?
 1a. If not, where is it located? *adjacent ROW*

2. Is telephone stubbed to the excess land?
 2a. If not, where is it located?

3. Is under ground service required?

4. Who is responsible for bringing telephone lines to the building? *Developer*

5. Is the telephone located in an existing easement?

6. Please add any additional information/comments regarding telephone:

FEES:

1. Are there any unusually expensive fees or assessments relating to the future development of this property?

No

2. If yes, please describe in detail and attach a schedule if available:

BUILDING CODES:

1. What are the building codes by which the architectural plans must comply with on the outlot/excess land?

Internation Building Code as amended by Kenai Municipal Code

1a. What is the date they were adopted:

2. What is the building permit fee schedule?

The fee for each building permit shall be paid to the City of Kenai as set forth in Table No. 1-A of the Kenai Municipal Code at 4.05.030(b)

3. Is the outlot/excess land located in a fire zone or district?

Select Yes/No

4. Are there any special fire department requirements in addition to standard plans?

No

SITE / LANDSCAPING:

1. Is there a landscaping ordinance in place?

Yes

2. Is there any special lighting requirements?

No

2a. If yes, please describe:

3. What type of solid waste disposal is permitted?

3a. Compaction:

Yes

3b. Bulk pick up:

Yes

3c. Front loader:

Select Yes/No

3d. Side loader:

Select Yes/No

3e. Rear loader:

Select Yes/No

3f. Who has the Jurisdiction of solid waste:

Private Service

3g. Is this adequate for Jurisdiction?

Select Yes/No

3h. Is a drain required in the trash area?

No

3i. Are hot and cold water hose bibs required in the trash area?

No

****Note: Wal-Mart requires a masonry trash enclosure for compactor, dumpster.**

SOILS / ENVIRONMENTAL:

1. Was the outlot(s) rough graded?	Yes
2. Was it compacted to Wal-Mart standard specifications?	Yes
3. Was the excess land rough graded, if applicable?	Select One
4. Was it compacted to Wal-Mart's specs?	Select Yes/No
5. Did the Phase 1 Environmental report indicate contamination?	Yes
3a. Report prepared by:	Shannon & Wilson, Inc.
3b. Dated:	Sep-07
3c. If yes, was the contamination located in close proximity to or within the outlot/excess land?	Yes
3d. If yes, was the contamination remediated as part of the overall project?	Yes
3e. Please provide any additional information/comments regarding the contamination:	<i>The Phase I ESA revealed no evidence of recognized environmental conditions, except for five oil stained areas, approximately 12 to 24 inches in diameter, observed along the west side of the property adjacent to Marathon Road. The oil stains were consistent with drips or leaks from parked vehicles. Soils were removed as part of construction.</i>

6. Is any portion of the outlot/excess land located in a flood plan and/or wetland area? No

6a. If yes, please describe:

TRAFFIC:

1. Average Daily Traffic: Kenai Spur Highway
10688 v.p.d.
2005 (year)

Civil Consultant: Please add any information and/or comments that you can think impact the development and/or title of the outlot/excess land:

The purpose of this "Fact Sheet" is to provide general information regarding the subject property. It is the prospective purchaser's obligation to perform the necessary due diligence to insure that the property is capable of meeting the intended use.

CONTACTS:

The last page should be all local contacts (from your cover sheet)

This property is listed with Jack White Commercial, Carl D. Kuhn, CCIM, SIOR. The recipient of this information should consult with the listing Broker regarding licensee disclosures prior to touring the facility.

Although Jack White Commercial and Carl D. Kuhn, CCIM, SIOR, have endeavored to include in this evaluation material information which they believe to be relevant for the purpose of helping a prospective buyer in its evaluation of the subject property for possible purchase, the recipient of these marketing materials understands and acknowledges that neither the owner nor Jack White Commercial nor Carl D. Kuhn, CCIM, SIOR, makes any representation as to the accuracy or completeness of this marketing material. The recipient of this information is strongly encouraged to consult professional engineers, attorneys, accountants, and/or other professionals with regards to the accuracy and veracity of this information.

The recipient of these marketing materials agrees that the owner, Jack White Commercial and Carl D. Kuhn, CCIM, SIOR, shall not have any liability to the recipient of these marketing materials as a result of their use. It is understood that the recipient is expected to perform, and is responsible for, such due diligence investigations and inspections of the subject property, including investigation of any environmental conditions, as the recipient deems necessary or desirable and as permitted by agreement with the owner.

This property is offered subject to prior offers, price changes, and/or withdrawal from the market without notice to prospective buyers.



THE STATE
of

ALASKA

Department of Commerce, Community, and Economic Development
Division of Corporations, Business and Professional Licensing

Real Estate Commission

550 West 7th Avenue, Suite 1500, Anchorage, AK 99501

Phone: (907) 269-8160

Email: RealEstateCommission@Alaska.Gov

Website: ProfessionalLicense.Alaska.Gov/RealEstateCommission

Alaska Real Estate Commission Consumer Disclosure

This is not a contract. This disclosure, as required by law, outlines the obligations of the Licensee to the Consumer and does not obligate the Consumer to the Licensee. This disclosure outlines the duties of the types of Licensee relationships identified by Alaska State law. (AS 08.88.600 - 08.88.695). The Consumer understands that they will be working with the Licensee under the relationship initialed below:

Specific Assistance	Representation
<p>The Consumer is receiving Specific Assistance without Representation. The Licensee does not represent the Consumer. Rather, the Licensee is simply responding to requests for information, and the Licensee may "Represent" another party in the transaction while providing you with Specific Assistance. Unless you and the Licensee agree otherwise, information you provide the Licensee is not confidential. Duties owed to the Consumer by the Licensee include:</p> <ul style="list-style-type: none"> a. Exercise of reasonable skill and care; b. Honest and good faith dealing; c. Timely presentation of all written communications; d. Disclosing all material information known by the Licensee regarding the physical condition of a property; and e. Timely accounting of all money and property received by the Licensee. <p>Consumer Initials: _____ / _____ Date: _____</p>	<p>The Licensee represents only the Consumer(s) listed in this disclosure unless otherwise agreed to in writing by all Consumers in a transaction. Duties owed to the Consumer by the Licensee include:</p> <ul style="list-style-type: none"> a. All duties owed by the Licensee providing Specific Assistance; b. Not intentionally taking actions which are adverse or detrimental to the Consumer; c. Timely disclosure of conflicts of interest to the Consumer; d. Advising the Consumer to seek independent expert advice if a matter is outside the expertise of the Licensee; e. Not disclosing confidential information during or after representation without written consent of the Consumer unless required by law; and f. Making a good faith and continuous effort. <p>Consumer Initials: _____ / _____ Date: _____</p>

Neutral Licensee

Alaska Law allows for a Licensee to assist the Seller/Lessor AND the Buyer/Lessee in a real estate transaction. It is understood that a Neutral License is NOT Representing either party and duties are limited. Duties owed to the Consumer by a Neutral Licensee include:

- a. All duties owed by the Licensee providing Specific Assistance;
- b. Duties a, b, c, d, and e, owed by the Licensee providing Representation; and
- c. Not disclosing the terms or the amount of money the Consumer is willing to pay or accept for a property if different than what the Consumer has offered or accepted for a property.

Consumer Initials: _____ / _____ Date: _____ (Must attach Waiver of Right to be Represented)

Duties Not Owed by Licensee

AS 08.88.630 - **Duties not owed by licensee.** Unless agreed otherwise, a real estate licensee does not owe a duty to a person with whom the licensee has established a licensee relationship to

- (1) conduct an independent inspection of the real estate that is the subject of the licensee relationship;
- (2) conduct an independent investigation of a person's financial condition; or
- (3) independently verify the accuracy or completeness of a statement made by a party to a real estate transaction or by a person reasonably believed by the licensee to be reliable.

Acknowledgement: The below Consumer has read the information provided in the Alaska Real Estate Disclosure and understands the different types of relationships available by an Alaska Real Estate Licensee. For full description of Licensee Relationships refer to AS 08.88.600 - 08.88.695.

Brokerage Name:					
Licensee Name:		Signature:		Date:	
Consumer Name:		Signature:		Date:	
Consumer Name:		Signature:		Date:	

An addendum ___ IS ___ IS NOT attached. If more than one Licensee is involved, a Consumer Disclosure Addendum shall be attached naming all Licensees and specifying the relationship.

– THIS CONSUMER DISCLOSURE IS NOT A CONTRACT –



Real Estate Commission

550 West 7th Avenue, Suite 1500, Anchorage, AK 99501

Phone: (907) 269-8160

Email: RealEstateCommission@Alaska.Gov

Website: ProfessionalLicense.Alaska.Gov/RealEstateCommission

Alaska Real Estate Commission Consumer Disclosure Addendum

This form shall be attached to the Alaska Real Estate Commission Consumer Disclosure if there is more than one Licensee in a relationship with the Consumer, in a single transaction.

Relationship(s) MUST be indicated for each Licensee listed below.

Specific Assistance without Representation = S

Representation = R

Neutral Licensee Relationship = N*

*If Neutral, the Waiver of Right to be Represented form (#08-4212) must be attached for each Licensee.

Additional Licensees			Relationship		
Name	Signature	Date	S	R	N*

TEAMS: If the aforementioned licensee(s) are a part of a team, the team name shall be listed below. The Consumer understands that the team below is NOT acting as a brokerage. "Team" means two or more Licensees within the same brokerage who work together as one unit under a collective name and provide services or perform activities that require a professional license in real estate.

Brokerage Name:

Team Name:

Acknowledgement: The below Consumer has read the information provided in the Alaska Real Estate Disclosure and understands the different types of relationships available by an Alaskan Real Estate Licensee. The Consumer further understands that the duties owed by a Licensee are limited by the relationship indicated.

Consumer Name:		Signature:		Date:	
Consumer Name:		Signature:		Date:	

– THIS CONSUMER DISCLOSURE IS NOT A CONTRACT –